

锁具/LOCK KIT

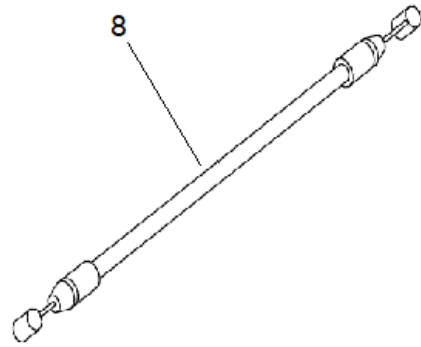

NO.	CODE	EN DESCRIPTION	QTY	REMARKS
F01-01	6AQV-011000-4000	LOCK KIT	1	
F01-02	30102-050008900	INNER HEX SCREW M5x8	2	
F01-03	30102-050025900	INNER HEX SCREW M5x25	3	
F01-04	6AQV-011020-4000	KEY	2	
F01-05	30102-080030810	SCREW M8X30	2	
F01-06	CFCV-CAC002-2000-M1	CLIP	1	
F01-07	30102-050012810	SCREW M5X12	2	
F01-08	6AQV-011012-1000	SEAT CABLE	1	
F01-09	6GU#-010320-6000	LOCK SEAT, SEAT	1	
F01-10	30006-060022810	BOLT M6X22	2	

消声器/MUFFLER

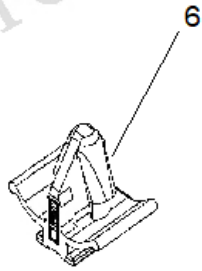
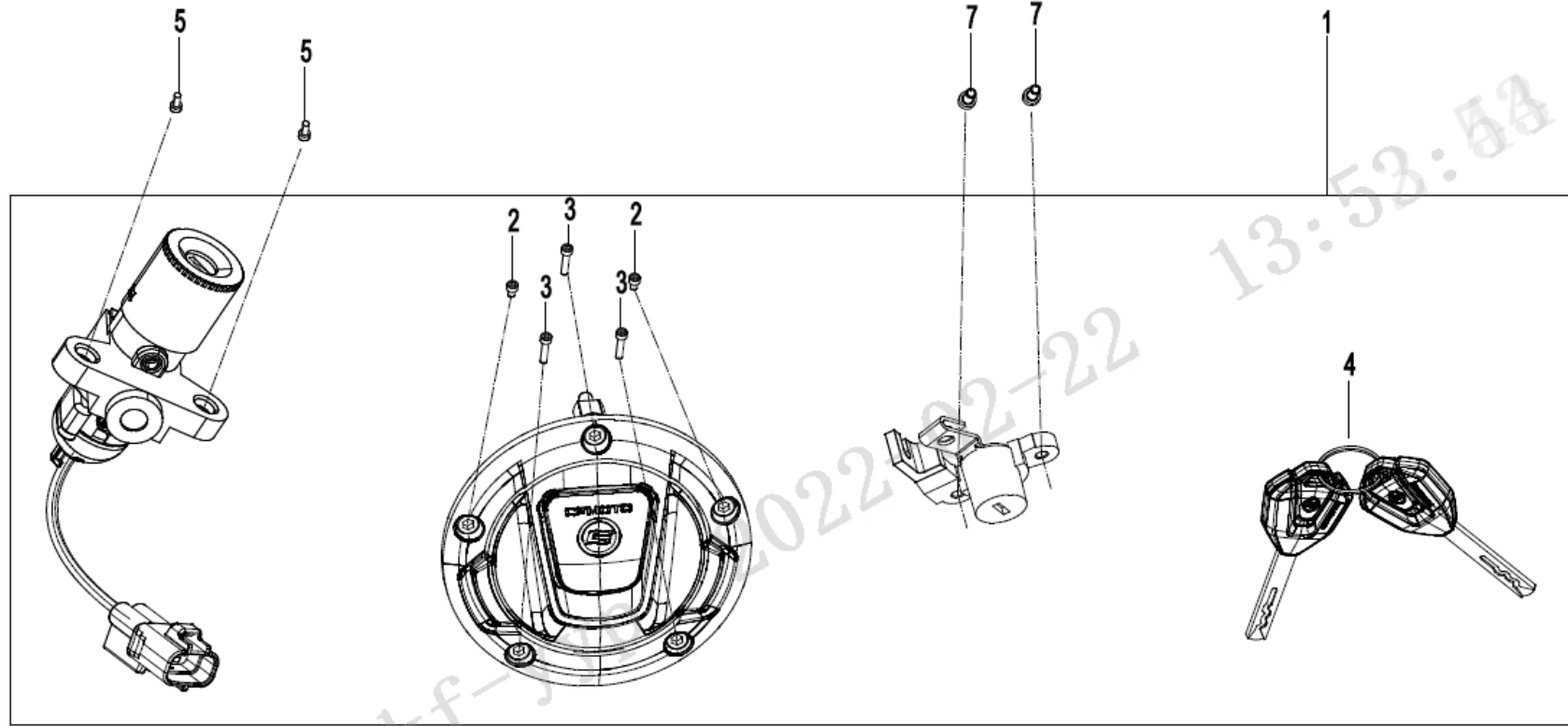
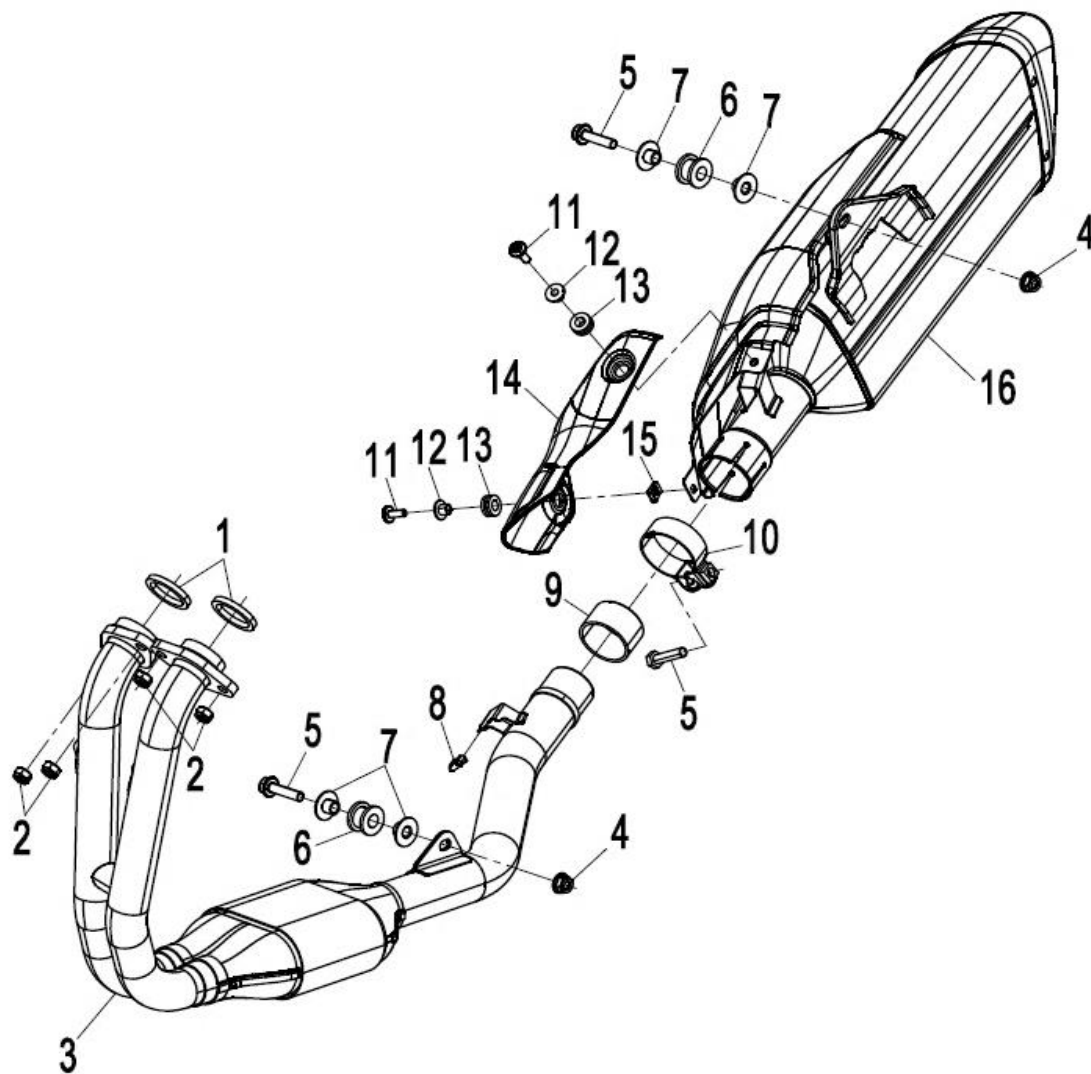

NO.	CODE	EN DESCRIPTION	QTY	REMARKS
F02-01	6090-020010	GASKET, EXHAUST PORT	2	
F02-02	6L30-020005	LOCK NUT	4	
F02-03	6AQV-021100-4000	EXHAUST PIPE ASSY	1	
F02-04	30204-080810	LOCK NUT M8	2	
F02-05	30006-080035810	BOLT M8X35	3	
F02-06	A000-020004	DAMPER, MUFFLER	2	
F02-07	A000-020005	BUSHING	4	
F02-08	6GU#-021005-6000	GUARD RUBBER SLEEVE	1	
F02-09	6AQV-021400-1000	SEAL SLEEVE, GRAPHITE	1	
F02-10	6AQV-021500-1000	CLAMP KIT	1	
F02-11	6WWV-046902-5000	INNER HEX SCREW M6x20	2	
F02-12	6AQV-021002-1000	BUSHING	2	
F02-13	6AQV-021003-1000	RUBBER BUSHING, GUARD	2	
F02-14	6AQV-021001-4000	MUFFLER GUARD	1	
F02-15	6AQV-021005-4000	M6 NUT CLIP	1	
F02-16	6AQV-021300-4002	MUFFLER BODY ASSY	1	

车架/FRAME

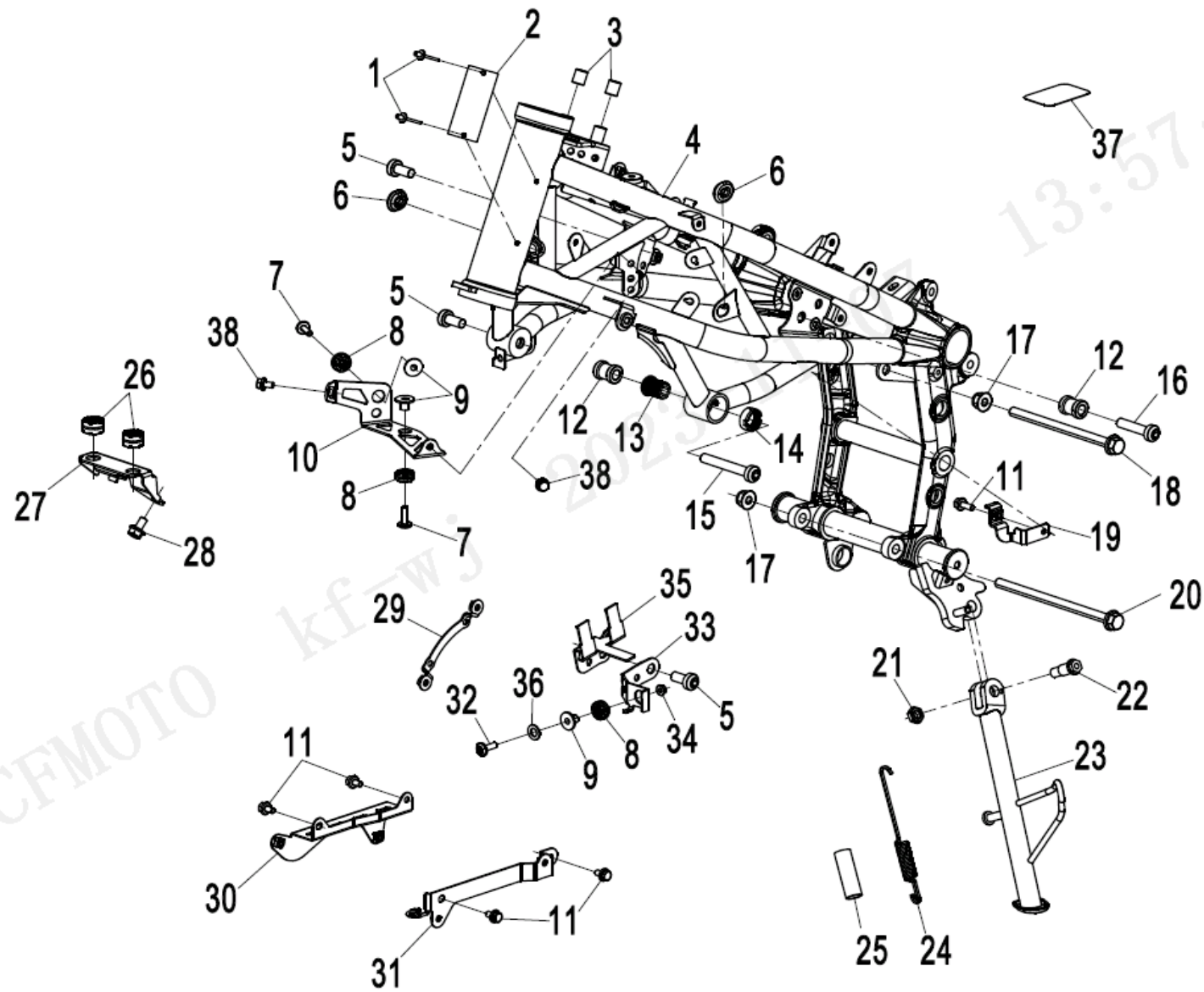

NO.	CODE	EN DESCRIPTION	QTY	REMARKS
F03-1-01	30902-0401320	RIVET GB/T12618_4.2X8	2	
F03-1-02	6FIA-190012	VIN PLATE	1	
F03-1-03	6KVV-030004-1000	POWER LOCK BUSHING	2	
F03-1-04	6AQV-031000-4001-0BP00	FRONT FRAME ASSY (MAUD SPIRIT BLACK)	1	
F03-1-05	6L30-030092	BOLT M10x22	3	
F03-1-06	6KVV-041114-1000	RUBBER HEAD	2	
F03-1-07	6WVV-046902-5000	INNER HEX SCREW M6x20	2	
F03-1-08	6WVV-030019-5000	CUSHION SLEEVE	3	
F03-1-09	9060-180029	RADIATOR SLEEVE TUBE	3	
F03-1-10	6AQV-030010-1000	BRACKET, ABS	1	
F03-1-11	30006-060010810	BOLT M6X10	5	
F03-1-12	6AQV-030004-1000	BUSHING, ENGINE	2	
F03-1-13	6AQV-030092-1000	ADJUSTING SCREW, ENGINE	1	
F03-1-14	6NT1-000292	NUT M18	1	
F03-1-15	6AQV-030093-1000	INNER HEX SCREW	1	
F03-1-16	6WVV-030011-5000	INNER HEX SCREW M10x45	1	
F03-1-17	30204-102810	NUT M10X1.25	2	
F03-1-18	30001-102150110	BOLT M10x1.25x150	1	
F03-1-19	6AQV-030003-4000	FLUID RESERVOIR BRACKET	1	
F03-1-20	30001-102170110	BOLT M10X1.25X170	1	
F03-1-21	30208-102010	NUT M10X1.25	1	
F03-1-22	6080-030004	SIDE STAND BOLT	1	
F03-1-23	6AQV-030600-4001-0BP00	SIDE STAND ASSY (MAUD SPIRIT BLACK)	1	
F03-1-24	A000-030210	SIDE STAND SPRING ASSY	1	
F03-1-25	A000-030004	SIDE STAND SPRING SLEEVE	1	
F03-1-26	6KVV-030003-1000	HEADLIGHT BRACKET SLEEVE	2	
F03-1-27	6AQV-030001-4000	HEADLIGHT LOWER BRACKET	1	
F03-1-28	30006-080016870	BOLT M8X16	1	
F03-1-29	6AQV-030060-4000	RESERVOIR BRACKET	1	
F03-1-30	6AQV-030040-4000	RH LOWER PANEL BRACKET, ENGINE	1	
F03-1-31	6AQV-030030-4000	LH LOWER PANEL BRACKET, ENGINE	1	
F03-1-32	6WVV-047002-5000	INNER HEX SCREW M6x25	1	

NO.	CODE	EN DESCRIPTION	QTY	REMARKS
F03-1-33	6AQV-030002-4001	HORN BRACKET	1	
F03-1-34	30204-060870	NUT M6	1	
F03-1-35	6AQV-030050-4001	CANISTER ADAPTER PLATE	1	
F03-1-36	30301-060470	WASHER 6	1	
F03-1-37	6AQV-041116-1000	FRAME STICKER	1	
F03-1-38	30006-060012810	BOLT M6X12	2	ALT:- 30006-060012870

F03车架总成/FRAME ASSY

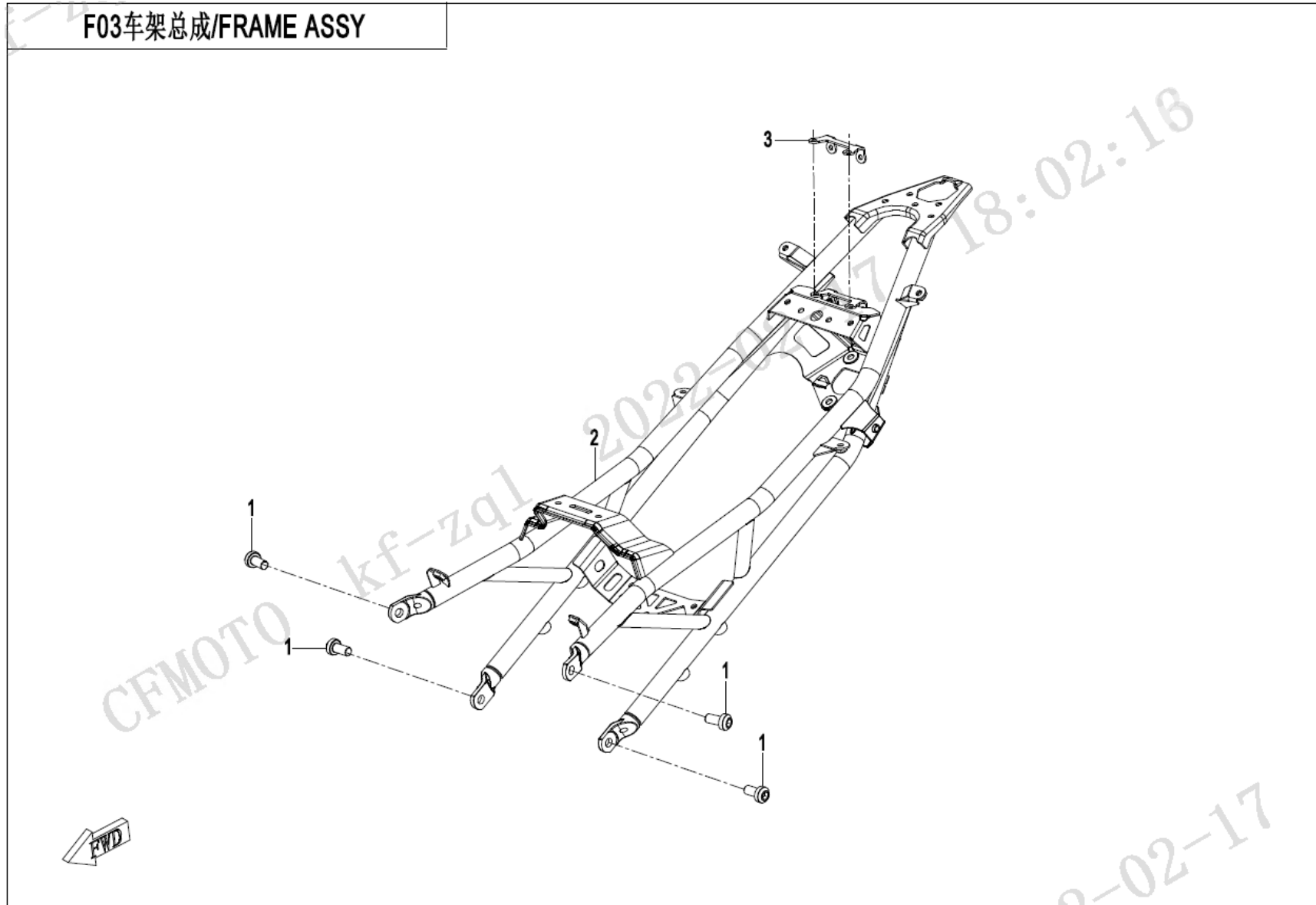

NO.	CODE	EN DESCRIPTION	QTY	REMARKS
F03-2-01	6GU#-030007-6000	REAR FRAME BOLT	4	
F03-2-02	6AQV-032000-1003-0BP00	REAR FRAME ASSY	1	
F03-2-03	6AQV-030017-1000	BRACKET, ROLL-OVER SENSOR	1	

变档杆/GEARSHIFT LEVER

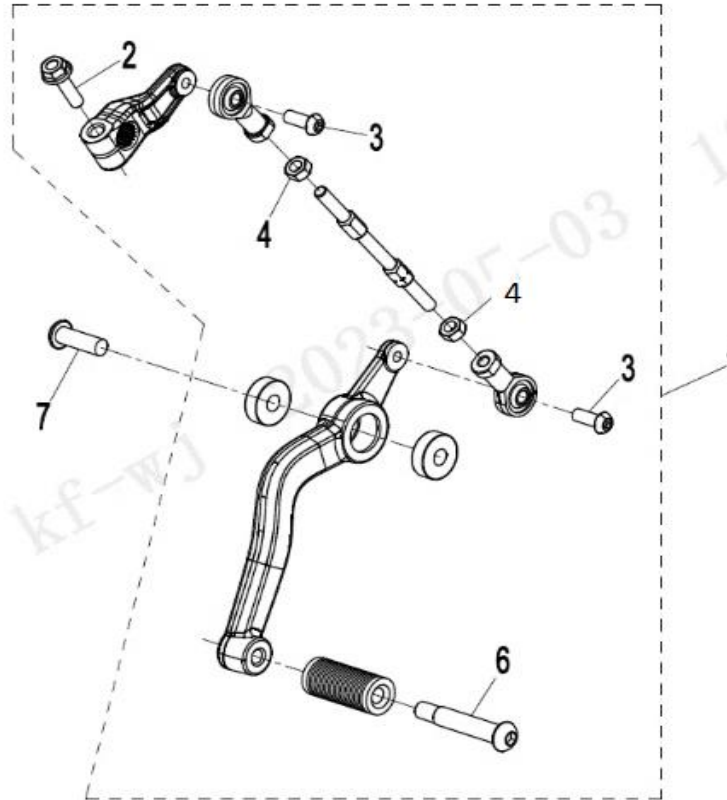

NO.	CODE	EN DESCRIPTION	QTY	REMARKS
F03-3-01	6AQV-141000-4000-0VR00	GEARSHIFT ROD CONNECTING ASSY (ELECTRO SILVER)	1	
F03-3-02	30006-060022810	BOLT M6X22	1	
F03-3-03	30121-060016700	SCREW M6x16	2	
F03-3-04	30200-060810	NUT M6	1	
F03-3-06	6NQ#-140104-6002	PEDAL BOLT	1	
F03-3-07	30121-080025160	SCREW M8X25	1	

塑料件 I / PLASTICS I

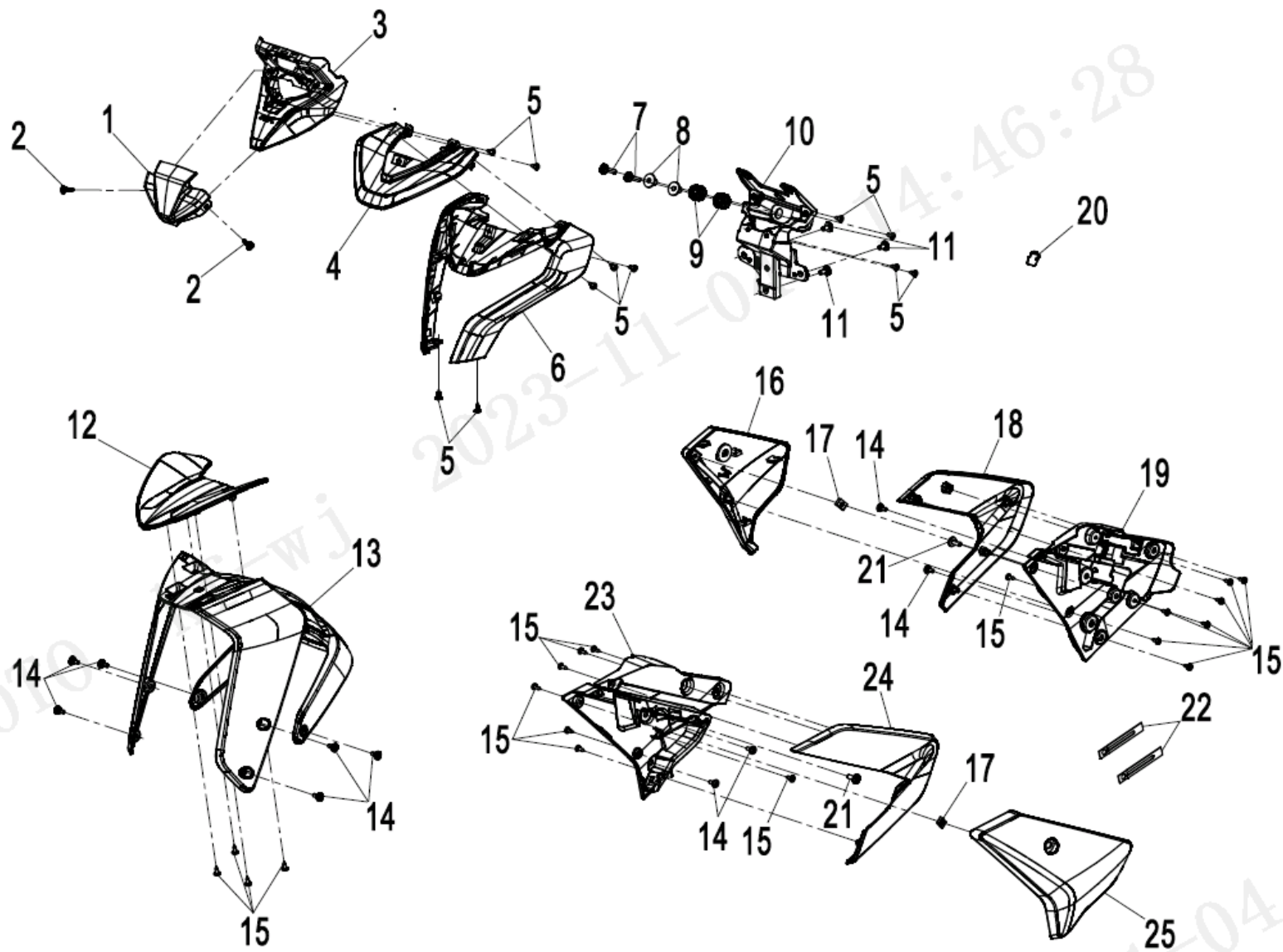

NO.	CODE	EN DESCRIPTION	QTY	REMARKS
F04-2-01	6AQV-040301-4000-0BU00	DASHBOARD DECO GUARD (MIST SILVER BLACK)	1	
F04-2-02	8080-041130	EXPANSION RIVET ASSY	2	ALT:- 8080-041131, 8080-041132
F04-2-03	6AQV-040203-4000	DASHBOARD UPPER DECO GUARD	1	
F04-2-04	6AQV-040201-4000-0VE00	HEADLIGHT UPPER DECO GUARD (NEBULA WHITE)	1	FOR WHITE BIKE
F04-2-04	6AQV-040201-4000-0HC00	HEADLIGHT DECO COVER (VELOCITY GREY)	1	FOR BLUE BIKE
F04-2-05	30110-420130070	SELF-TAPPING SCREW ST4.2X13	11	
F04-2-06	6AQV-040202-4000-0BU00	HEADLIGHT DECO GUARD (MIST SILVER BLACK)	1	FOR WHITE BIKE
F04-2-06	6AQV-040202-4000-0VE00	HEADLIGHT DECO GUARD (NEBULA WHITE)	1	FOR BLUE BIKE
F04-2-07	6WWV-047002-5000	INNER HEX SCREW M6x25	2	
F04-2-08	5020-031002	RUBBER SLEEVE LINER, FRONT LICENSE BRACKET	2	
F04-2-09	5020-031001	RUBBER SLEEVE, FRONT LICENSE BRACKET	2	
F04-2-10	6AQV-040302-4000	DASHBOARD LOWER DECO GUARD	1	
F04-2-11	6WWV-046702-5000	INNER HEX SCREW M6x12	3	
F04-2-12	6KWV-050702-1000-0EN00	FRONT FENDER DECO PLATE (ZEPHYR BLUE)	1	FOR BLUE BIKE
F04-2-12	6KWV-050702-1000-0VE00	FRONT FENDER DECO PLATE (NEBULA WHITE)	1	FOR WHITE BIKE
F04-2-13	6KWV-050701-1000-0BU00	FRONT FENDER (MIST SILVER BLACK)	1	
F04-2-14	6WWV-046502-5000	SCREW M5	10	
F04-2-15	30110-421130010	SELF-TAPPING SCREW ST4.2X13	19	
F04-2-16	6AQV-040502-4000	RADIATOR RH PANEL	1	
F04-2-17	8010-000002	TOOL ST4.2	2	
F04-2-18	6AQV-040506-4000-0BM00	RADIATOR RH DECO PLATE (NEBULA BLACK)	1	
F04-2-19	6AQV-040504-4000	RADIATOR RH INNER PANEL	1	
F04-2-20	6AQV-041117-1002	STEPPED SCREW M5	1	
F04-2-21	6WWV-046802-5000	INNER HEX SCREW M6x16	2	
F04-2-22	0180-014010	WIRE CLIP	2	
F04-2-23	6AQV-040503-4000	RADIATOR LH INNER PANEL	1	
F04-2-24	6AQV-040505-4000-0BM00	RADIATOR LH DECO PLATE (NEBULA BLACK)	1	
F04-2-25	6AQV-040501-4000	RADIATOR LH PANEL	1	

塑料件 II / PLASTICS II

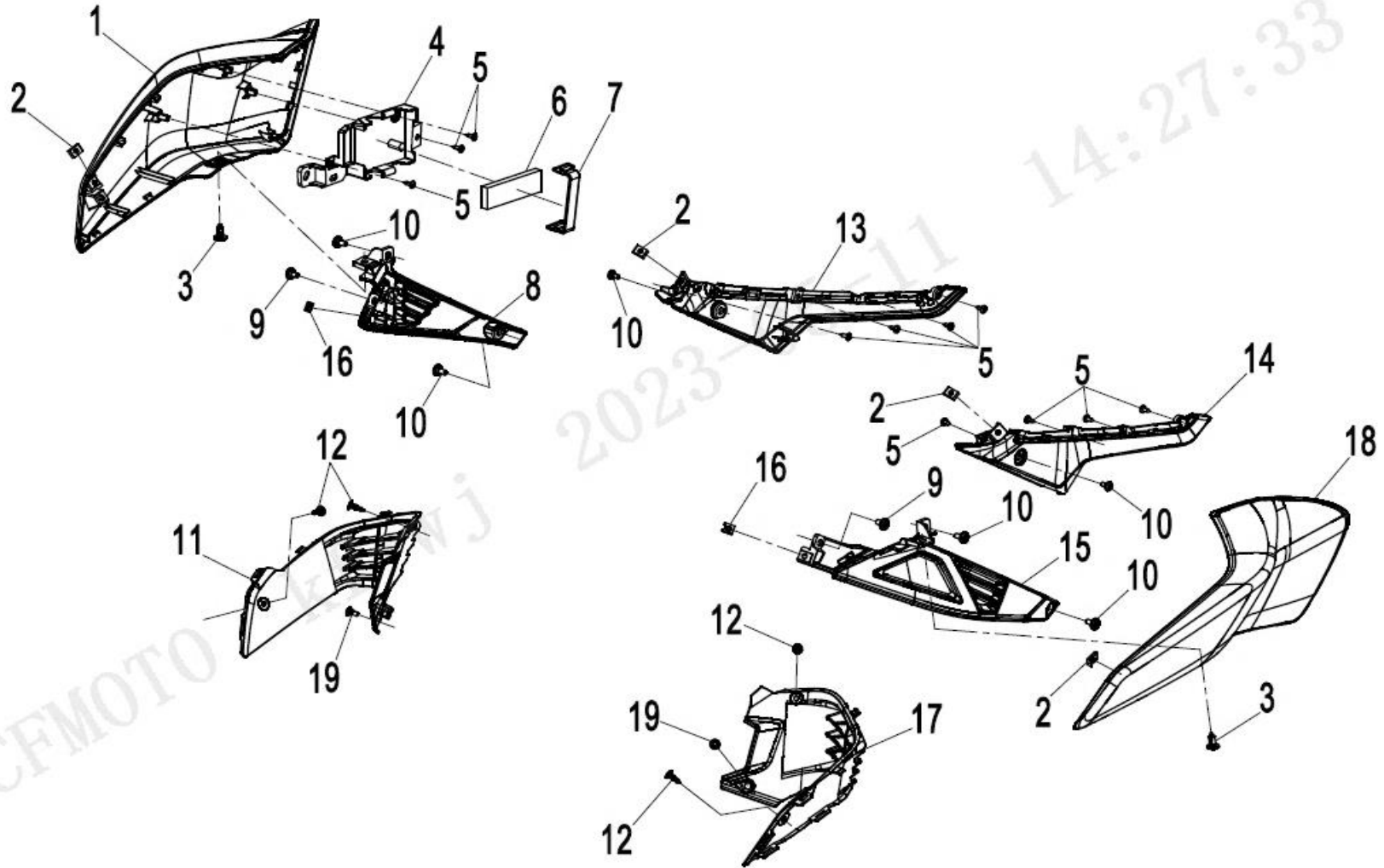

2023-05-11

NO.	CODE	EN DESCRIPTION	QTY	REMARKS
F04-2-01	6AQV-040407-4000-0VE00	FUEL TANK RH FRONT GUARD (NEBULA WHITE)	1	FOR BLUE BIKE
F04-2-01	6AQV-040407-4000-0D500	FUEL TANK RH FRONT GUARD (SAPPHIRE BLACK)	1	FOR WHITE BIKE
F04-2-02	8010-000002	TOOL ST4.2	4	
F04-2-03	9060-040310	PLASTIC CLIPS	2	
F04-2-04	6AQV-041511-4000	T-BOX BRACKET	1	
F04-2-05	30110-421130010	SELF-TAPPING SCREW ST4.2X13	11	
F04-2-06	6KWV-041108-1000	BATTERY FRONT SPONGE MAT	1	
F04-2-07	6GUV-150910-9000	T-BOX ASSY	1	
F04-2-08	6AQV-040602-4000	VEHICLE RH LOWER PANEL	1	
F04-2-09	6WWV-046502-5000	STEPPED SCREW M5	2	
F04-2-10	6WWV-046602-5000	INNER HEX STEPPED SCREW M6x14	6	
F04-2-11	6AQV-040413-4001	RH INNER GUARD, FUEL TANK	1	
F04-2-12	8080-041130	EXPANSION RIVET ASSY	4	ALT:- 8080-041131, 8080-041132
F04-2-13	6AQV-040411-4000	FUEL TANK RH LOWER DECO STRIP	1	
F04-2-14	6AQV-040410-4000	FUEL TANK LH LOWER DECO STRIP	1	
F04-2-15	6AQV-040601-4000	VEHICLE LH LOWER PANEL	1	
F04-2-16	6KM#-040081-8000-M1	NUT CLIP M5	2	
F04-2-17	6AQV-040412-4001	LH INNER GUARD, FUEL TANK	1	
F04-2-18	6AQV-040406-4000-0VE00	FUEL TANK LH FRONT GUARD (NEBULA WHITE)	1	FOR BLUE BIKE
F04-2-18	6AQV-040406-4000-0D500	FUEL TANK LH FRONT GUARD (SAPPHIRE BLACK)	1	FOR WHITE BIKE
F04-2-19	6WWV-047102-5000	INNER HEX SCREW M5x14	2	

塑料件 III/PLASTICS III

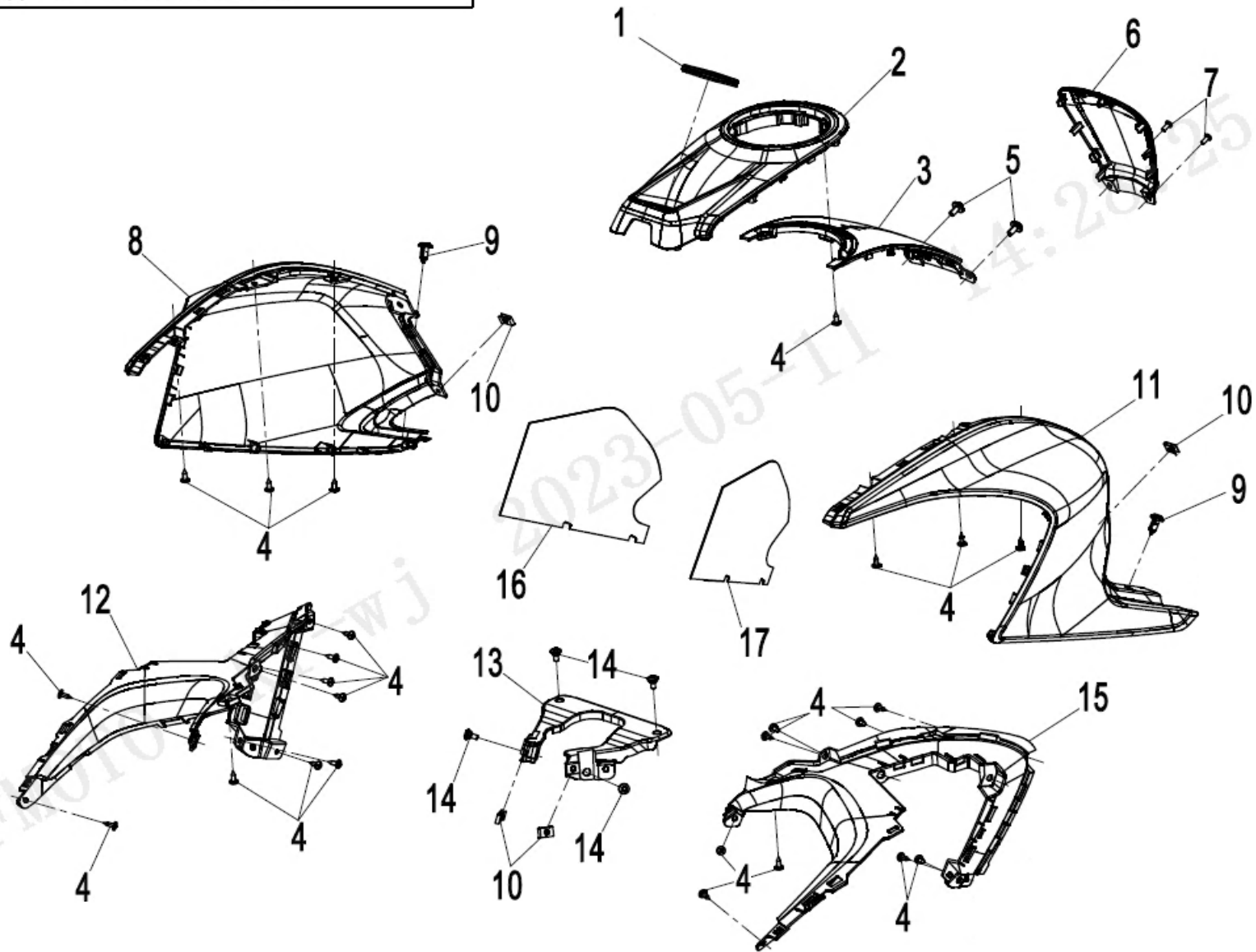

NO.	CODE	EN DESCRIPTION	QTY	REMARKS
F04-3-01	6AQV-040414-4000	IGNITION LOCK RUBBER RING	1	
F04-3-02	6AQV-040401-4000	FUEL TANK FRONT GUARD	1	
F04-3-03	6AQV-040404-4001-0VE00	FUEL TANK MIDDLE GUARD (NEBULA WHITE)	1	FOR WHITE BIKE
F04-3-03	6AQV-040404-4001-0EN00	FUEL TANK MIDDLE GUARD (ZEPHYR BLUE)	1	FOR BLUE BIKE
F04-3-04	30110-421130010	SELF-TAPPING SCREW ST4.2X13	25	
F04-3-05	6WWV-046702-5000	INNER HEX SCREW M6x12	2	
F04-3-06	6AQV-040405-4000	FUEL TANK REAR GUARD	1	
F04-3-07	30118-420095010	SELF-TAPPING SCREW ST4.2x9.5	2	
F04-3-08	6AQV-040403-4001-0VE00	FUEL TANK RH GUARD (NEBULA WHITE)	1	FOR WHITE BIKE
F04-3-08	6AQV-040403-4001-0EN00	FUEL TANK RH GUARD (ZEPHYR BLUE)	1	FOR BLUE BIKE
F04-3-09	9060-040310	PLASTIC CLIPS	2	
F04-3-10	8010-000002	TOOL ST4.2	4	
F04-3-11	6AQV-040402-4001-0VE00	FUEL TANK LH GUARD (NEBULA WHITE)	1	FOR WHITE BIKE
F04-3-11	6AQV-040402-4001-0EN00	FUEL TANK LH GUARD (ZEPHYR BLUE)	1	FOR BLUE BIKE
F04-3-12	6AQV-040409-4000	FUEL TANK RH DECO STRIP	1	
F04-3-13	6AQV-040415-4000	FUEL TANK GUARD BRACKET	1	
F04-3-14	6WWV-046602-5000	INNER HEX STEPPED SCREW M6x14	4	
F04-3-15	6AQV-040408-4000	FUEL TANK LH DECO STRIP	1	
F04-3-16	6AQV-040417-4001	VEHICLE RH HEAT INSULATION STICKER	1	
F04-3-17	6AQV-040416-4001	VEHICLE LH HEAT INSULATION STICKER	1	

塑料件 IV/PLASTICS IV

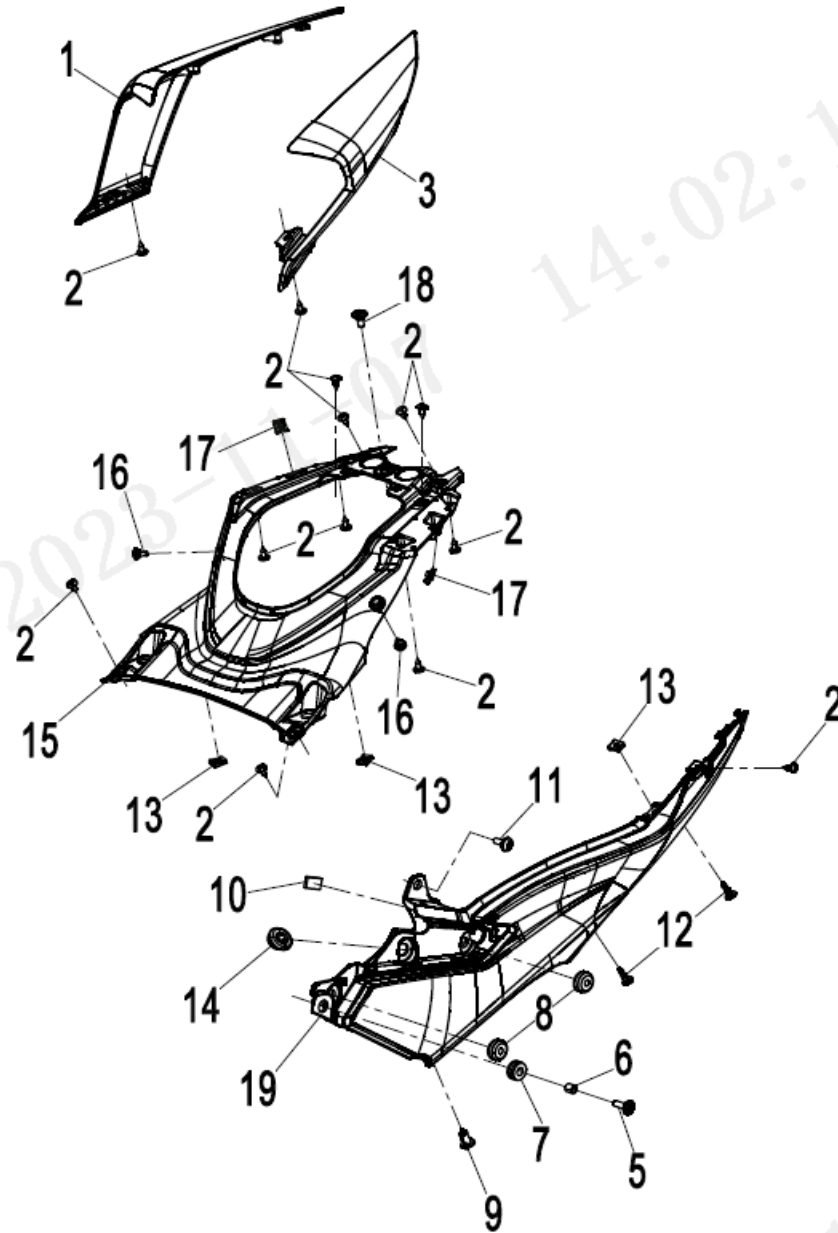
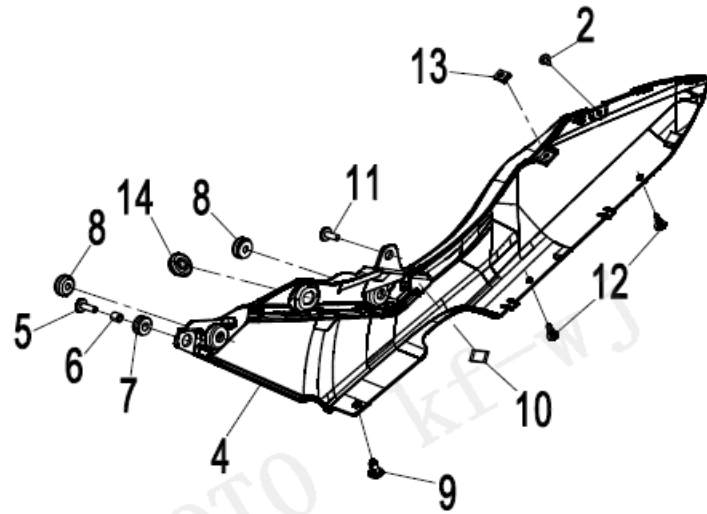

11-07

NO.	CODE	EN DESCRIPTION	QTY	REMARKS
F04-4-01	6AQV-040704-1001-0VE00	RH GUARD, TAIL LIGHT (NEBULA WHITE)	1	
F04-4-01	6AQV-040704-1001-0EN00	RH GUARD, TAIL LIGHT (ZEPHYR BLUE)	1	
F04-4-02	30110-481130070	SELF-TAPPING SCREW	14	
F04-4-03	6AQV-040703-1001-0VE00	LH GUARD, TAIL LIGHT (NEBULA WHITE)	1	
F04-4-03	6AQV-040703-1001-0EN00	LH GUARD, TAIL LIGHT (ZEPHYR BLUE)	1	
F04-4-04	6AQV-040702-4001	RH VEHICLE COVER	1	
F04-4-05	6WWV-046902-5000	INNER HEX SCREW M6x20	2	
F04-4-06	6090-040303	BUSHING	2	
F04-4-07	6090-040302	CUSHION SLEEVE	2	
F04-4-08	A000-040302	RUBBER DAMPER	4	
F04-4-09	9060-040310	PLASTIC CLIPS	2	
F04-4-10	6KM#-160420-8001	SPONGE MAT	2	
F04-4-11	6WWV-046702-5000	SCREW	2	
F04-4-12	8080-041130	EXPANSION RIVET ASSY	4	ALT:- 8080-041131, 8080-041132
F04-4-13	8080-000002	CLIP NUT ST4.8	4	
F04-4-14	8080-040064	FRONT FENDER DAMPER	2	
F04-4-15	6AQV-040706-1001	LOWER PANEL, SEAT	1	
F04-4-16	6WWV-046502-5000	STEPPED SCREW M5	2	
F04-4-17	6KM#-040081-8000-M1	NUT CLIP M5	2	
F04-4-18	6WWV-046602-5000	INNER HEX STEPPED SCREW M6x14	1	
F04-4-19	6AQV-040701-4001	LH VEHICLE COVER	1	

塑料件 V/PLASTICS V

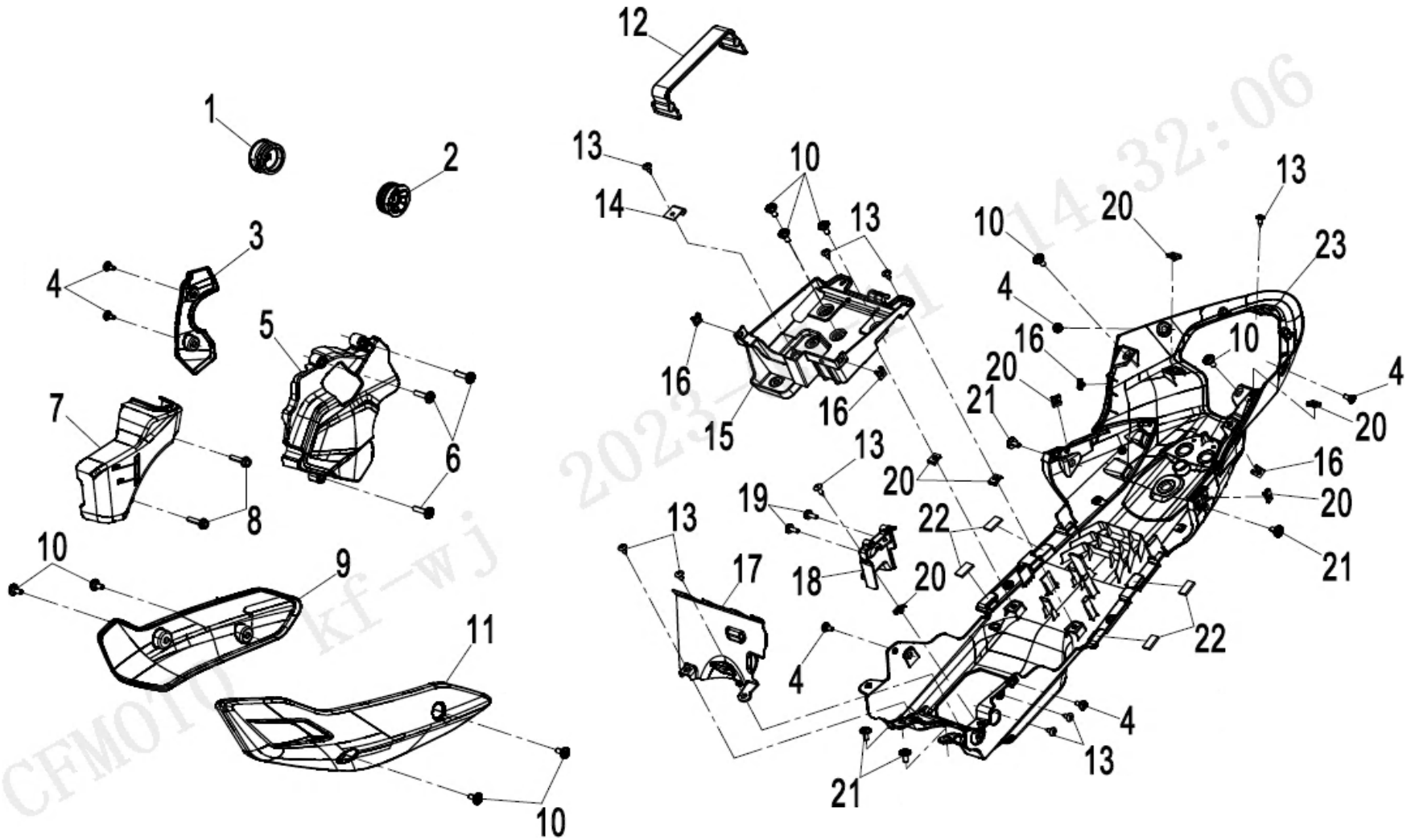

05-11

NO.	CODE	EN DESCRIPTION	QTY	REMARKS
F04-5-01	6AQV-040304-4000	FRAME RH DECO COVER	1	
F04-5-02	6AQV-040303-4000	FRAME LH DECO COVER	1	
F04-5-03	6AQV-040603-4000	VEHICLE RH DECO PLATE	1	
F04-5-04	6WWV-046502-5000	STEPPED SCREW M5	6	
F04-5-05	6AQV-041101-4000	SMALL SPROCKET GUARD	1	
F04-5-06	6WWV-047002-5000	INNER HEX SCREW M6x25	3	
F04-5-07	6AQV-040507-4000	RESERVOIR GUARD	1	
F04-5-08	30006-060025870	BOLT GB/T5789_M6X25	2	
F04-5-09	6AQV-040902-4000	RH LOWER PANEL, ENGINE	1	
F04-5-10	6WWV-046602-5000	INNER HEX STEPPED SCREW M6x14	9	
F04-5-11	6AQV-040901-4000	LH LOWER PANEL, ENGINE	1	
F04-5-12	6060-150700	TIE BAND, BATTERY	1	
F04-5-13	30110-481130070	SELF-TAPPING SCREW	9	
F04-5-14	A000-030005	TIE BAND BRACKET, TOOLS KIT	1	
F04-5-15	6AQV-041101-1001	BATTERY BOX	1	
F04-5-16	6KM#-040081-8000-M1	NUT CLIP M5	4	
F04-5-17	6AQV-041118-1002	HEAT INSULATOR, BATTERY	1	
F04-5-18	6AQV-041102-1000	SEAT LOCK GUARD	1	
F04-5-19	6WWV-047102-5000	INNER HEX SCREW M5x14	2	
F04-5-20	8080-000002	CLIP NUT ST4.8	7	
F04-5-21	6WWV-046702-5000	INNER HEX SCREW M6x12	4	
F04-5-22	6KM#-160420-8001	SPONGE MAT	4	
F04-5-23	6AQV-040705-1001	FRAME BASE PLATE	1	

塑料件 VI/PLASTICS VI

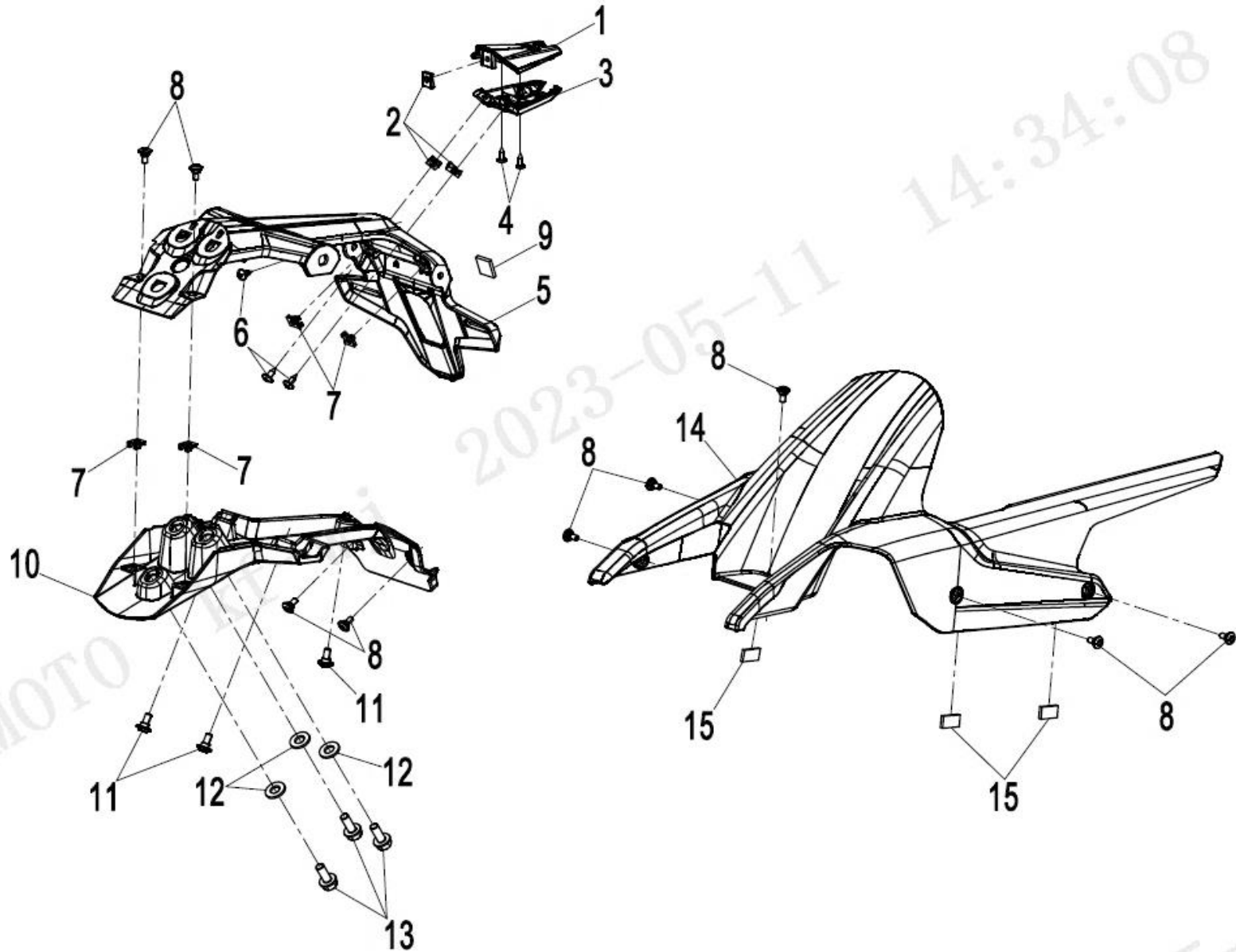

NO.	CODE	EN DESCRIPTION	QTY	REMARKS
F04-6-01	6AQV-040803-1001	UPPER COVER, LICENSE LIGHT	1	
F04-6-02	8080-000002	CLIP NUT ST4.8	3	
F04-6-03	6AQV-040804-1001	LOWER COVER, LICENSE LIGHT	1	
F04-6-04	30110-421130010	SELF-TAPPING SCREW	2	
F04-6-05	6AQV-040801-1000	UPPER PART, REAR FENDER	1	
F04-6-06	30110-420130070	SELF-TAPPING SCREW	3	
F04-6-07	6KM#-040081-8000-M1	NUT CLIP M5	4	
F04-6-08	6WWV-046502-5000	STEPPED SCREW M5	9	
F04-6-09	6NT1-041510	BUCKLE ASSY	2	
F04-6-10	6AQV-040802-1000	LOWER PART, REAR FENDER	1	
F04-6-11	6WWV-046602-5000	INNER HEX STEPPED SCREW M6x14	3	
F04-6-12	30306-100112	WASHER	3	
F04-6-13	30006-080020810	BOLT	3	
F04-6-14	6AQV-060401-1000	PANEL, REAR FORK	1	
F04-6-15	6KM#-160420-8001	SPONGE MAT	3	

前悬架/Front Suspension

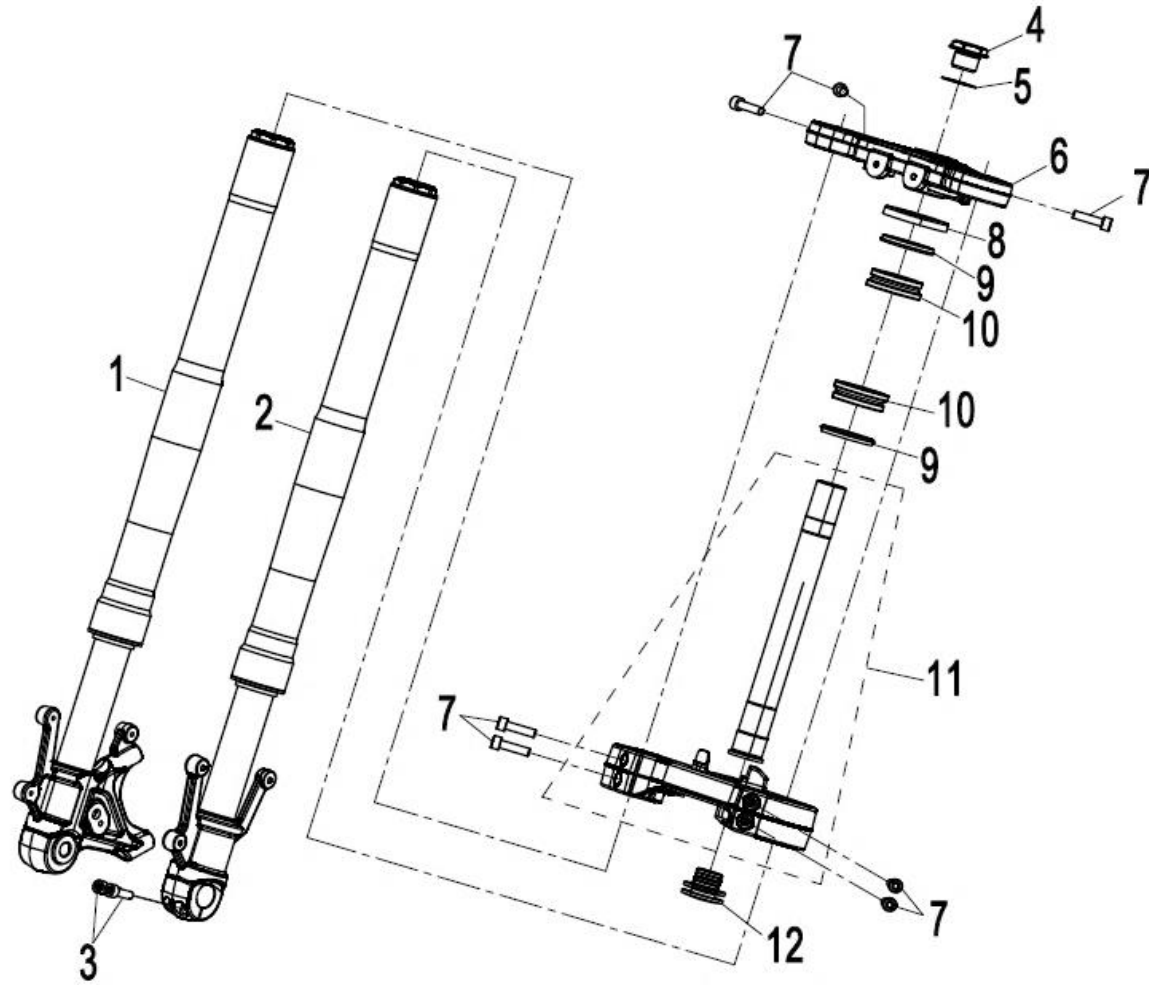

NO.	CODE	EN DESCRIPTION	QTY	REMARKS
F05-01	6AQV-050600-4000-M1	FRONT RH SHOCK ABSORBER	1	
F05-02	6AQV-050500-4000-M1	FRONT LH SHOCK ABSORBER	1	
F05-03	30102-080025700	SCREW M8x25	2	
F05-04	6L30-050002	LOCK SCREW, UPPER TRIPLE CLAMP	1	
F05-05	6WWV-050005-5000	WASHER	1	
F05-06	6AQV-050001-4001-0VR00	UPPER TRIPLE CLAMP (ELECTRO SILVER)	1	
F05-07	30102-080030860	SCREW M8X30	7	
F05-08	6L30-050003	DUST-PROOF COVER	1	
F05-09	6AQV-050010-1000	ANTI-DUST RING	2	
F05-10	6L30-050200	STEERING BEARING ASSY	2	
F05-11	6AQV-0503B0	LOWER TRIPLE CLAMP ASSY	1	
F05-12	A000-050011	RUBBER PLUG 2	1	

后悬架/REAR SUSPENSION

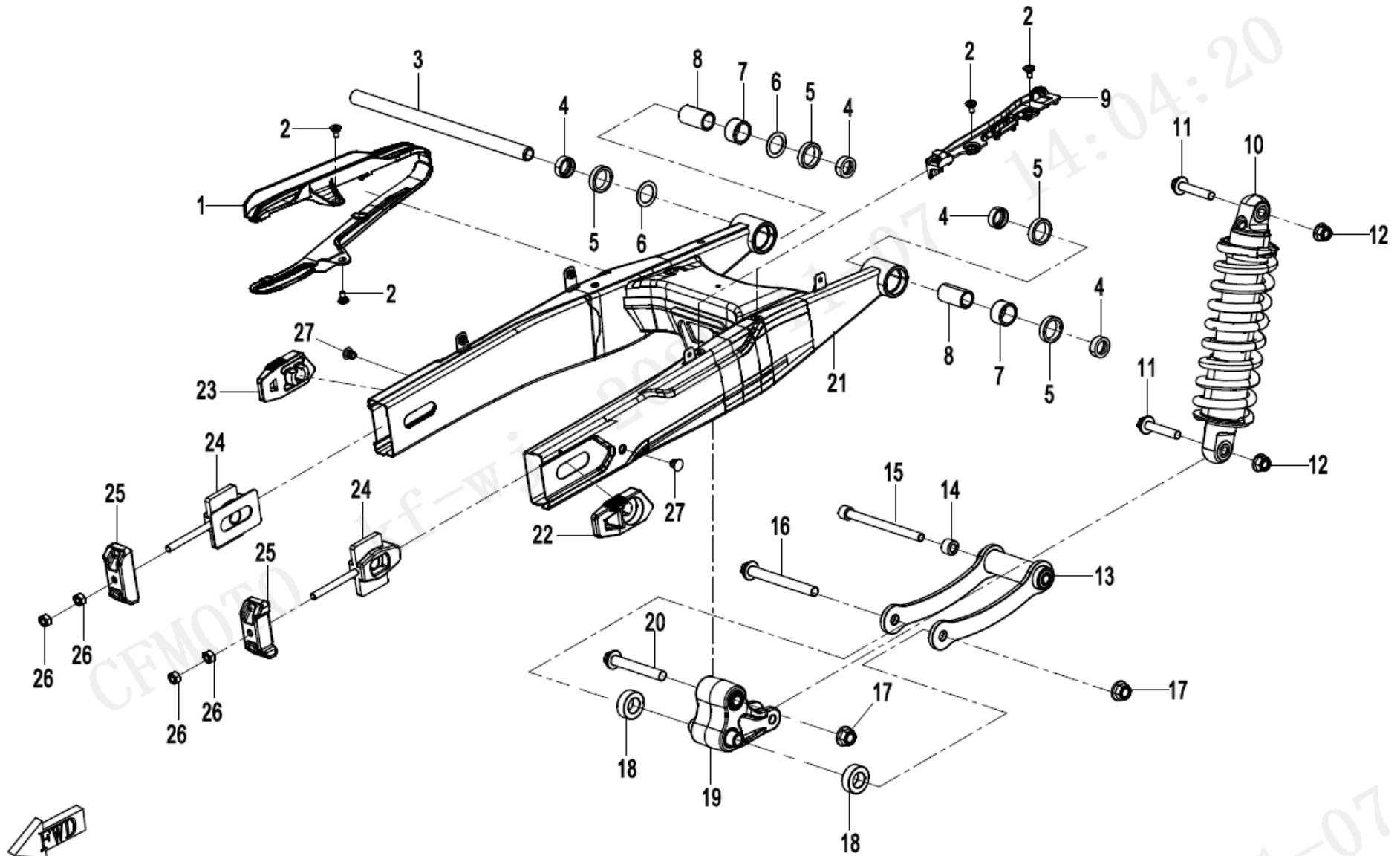

NO.	CODE	EN DESCRIPTION	QTY	REMARKS
F06-01	6AQV-060303-1000	CHAIN GUARD	1	
F06-02	6WWV-046502-5000	STEPPED SCREW M5	4	
F06-03	6AQV-060007-1000	REAR FORK SHAFT	1	
F06-04	6WWV-060030-5000-10	OIL SEAL	4	
F06-05	6WWV-060002-5000	BUSHING, REAR SWING ARM	4	
F06-06	6WWV-060004-5000	WASHER, REAR SWING ARM	2	
F06-07	30403-02280	NEEDLE BEARING	2	
F06-08	6WWV-060003-5000	LINER, REAR SWING ARM	2	
F06-09	6AQV-060304-1000	WIRE CLIP, BRAKE FLUID HOSE	1	
F06-10	6AQV-060100-1002-M2	SHOCK ABSORBER	1	
F06-11	6AQV-060004-1002	REAR SHOCK ABSORBER BOLT M10X50	2	
F06-12	30204-102810	NUT M10X1.25	2	
F06-13	6AQV-060600-1001	TIE ROD	1	
F06-14	6AQV-060005-1000	SPACER, TIE ROD	1	
F06-15	6AQV-060009-1002	TIE ROD BOLT M10X130	1	
F06-16	30024-122110110	BOLT	1	
F06-17	30204-122810	NUT M12X1.25	2	
F06-18	6AQV-060504-1000	RETAINER	2	
F06-19	6AQV-060550-1000	A-SHAPE SWING ARM ASSY	1	
F06-20	6AQV-060008-1002	A-SHAPE SWING ARM BOLT M12X80	1	
F06-21	6AQV-060300-1004-0BP00	REAR FORK ASSY (MAUD SPIRIT BLACK)	1	ALT:- 6AQV-060300-1003-0BP00
F06-22	6AQV-060045-1001-0VR00	RH CHAIN ADJUSTING DECO BLOCK (MERCURY SILVER)	1	
F06-23	6AQV-060044-1001-0VR00	LH CHAIN ADJUSTING DECO BLOCK (MERCURY SILVER)	1	
F06-24	6AQV-060043-1000	CHAIN ADJUSTING BLOCK	2	
F06-25	6AQV-060041-1000-0BP00	GUARD, CHAIN ADJUSTER (MAUD SPIRIT BLACK)	2	
F06-26	30200-080810	NUT M8	4	
F06-27	6KM#-100002-8000	PLUG	2	

F07前轮杆/FRONT WHEEL

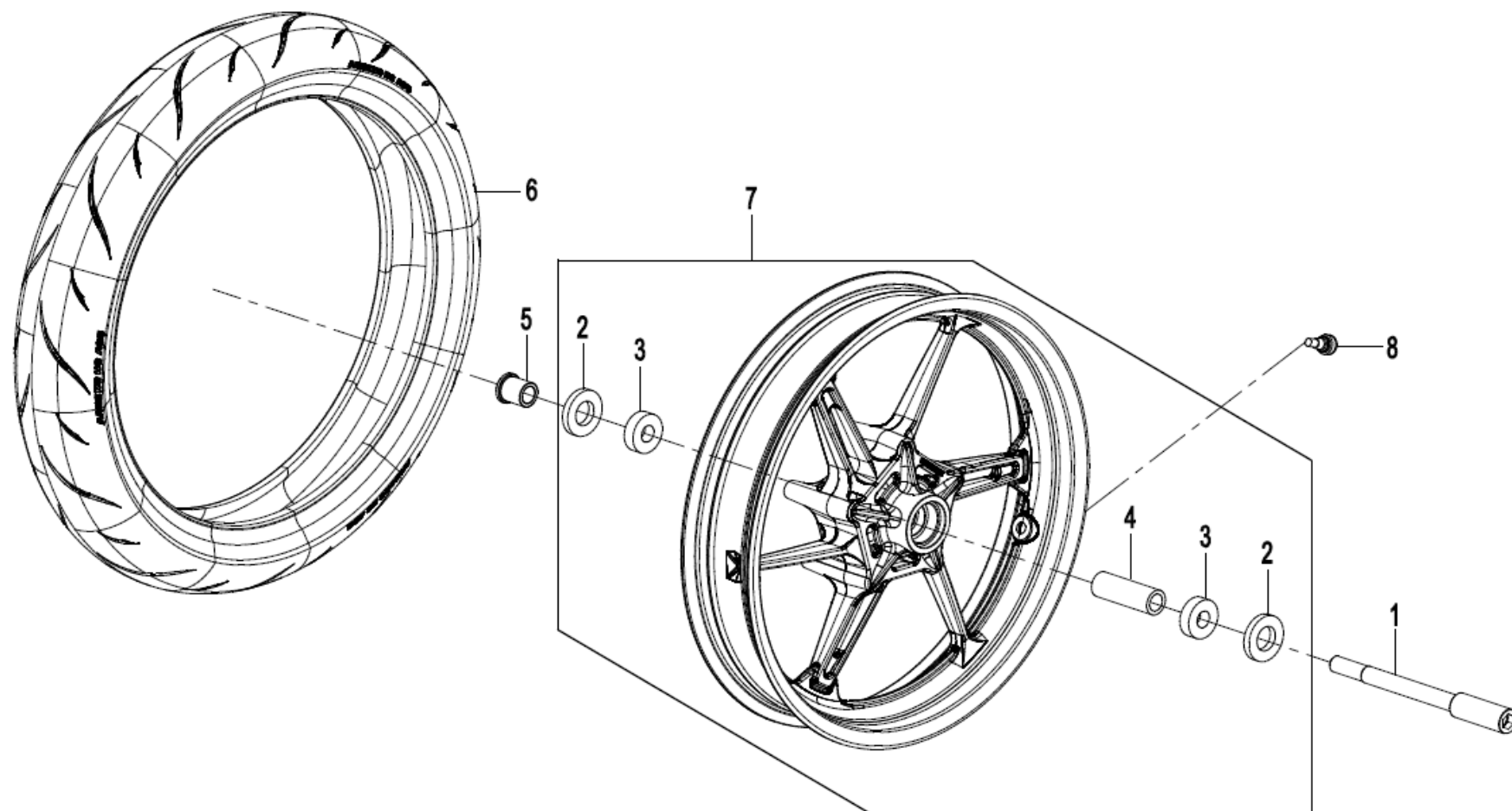

NO.	CODE	EN DESCRIPTION	QTY	REMARKS
F07-01	6AQV-070003-1001	FRONT WHEEL AXLE	1	ALT:- 6AQV-070003-1000
F07-02	6AQV-070200-1000-20	OIL SEAL	2	
F07-03	30400-01785	BEARING	2	
F07-04	6AQV-070202-1000-M1	MIDDLE SPACER, FRONT RIM	1	
F07-05	6AQV-070002-1000	FRONT WHEEL SHAFT BUSHING	1	
F07-06	30705SH-177500	TIRE	1	
F07-07	6AQV-070200-1001-M1-0BV00	FRONT RIM ASSY	1	
F07-08	5190-070030-1000	VALVE, INFLATION	1	

制动系统/BRAKE SYSTEM

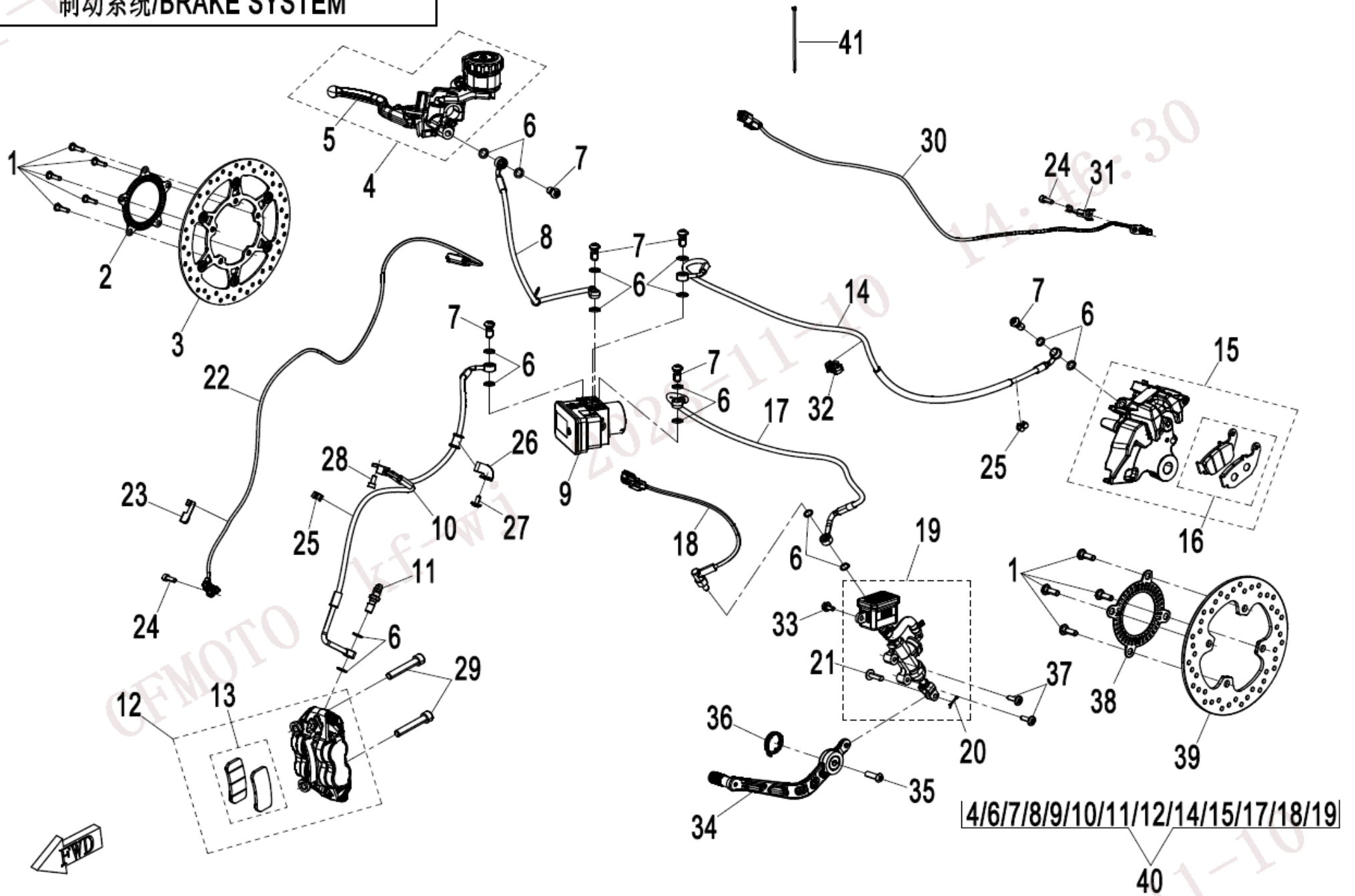

NO.	CODE	EN DESCRIPTION	QTY	REMARKS
F08-01	6KJ0-080005	FRONT BRAKE DISC BOLT	9	
F08-02	6AQV-080002-1000	"FRONT GEAR RING	1	
F08-03	6AQV-080001-1000-M1	FRONT BRAKE DISC	1	
F08-04	6AQV-081100-4001-M1	FRONT BRAKE MASTER CYLINDER ASSY	1	
F08-05	6AQV-081110-1000-47	BRAKE LEVER	1	
F08-06	6AQV-080102-1000-M1	WASHER	16	
F08-07	6AQV-080008-1000-M1	BANJO BOLT 2	6	
F08-08	6AQV-081500-4001	FRONT BRAKE FLUID OUTLET HOSE	1	
F08-09	6AQV-081300-5100-M1	ABS CONTROLLER	1	
F08-10	6AQV-081600-4000	FRONT BRAKE FLUID INLET PIPE	1	
F08-11	6AQV-080007-1000-M1	BANJO BOLT 1	1	
F08-12	6WWV-081200-5001	FRONT RH BRAKE CALIPER	1	
F08-13	6GUV-0811A0-6000	FRONT BRAKE PAD ASSY	1	SAME WITH 6GU#-0811A0-6000
F08-14	6AQV-081900-1000	FLUID INLET HOSE, REAR BRAKE	1	
F08-15	6AQV-081710-1001-M1	REAR BRAKE CALIPER	1	
F08-16	6KMO-0911B0	REAR BRAKE PAD ASSY	1	
F08-17	6AQV-081800-4001	FRONT BRAKE FLUID OUTLET HOSE	1	
F08-18	6GUV-081070-5000-M1	REAR BRAKE LIGHT SWITCH	1	
F08-19	6AQV-081400-4000-M1	REAR BRAKE MASTER CYLINDER ASSY	1	
F08-20	30903-0201610	COTTER PIN	1	
F08-21	30904-0602240	PIN SHAFT	1	
F08-22	6AQV-080004-1000-M2	FRONT SPEED SENSOR	1	
F08-23	6AQV-081002-4000	FRONT SPEED SENSOR WIRE CLIP	1	
F08-24	30102-060016870	SCREW M6x16	2	
F08-25	6KJ0-080003-00001	"BRAKE HOSE CLIP	6	
F08-26	6AQV-081601-1002	WIRE CLIP, FLUID INLET HOSE	1	
F08-27	30102-050012810	SCREW M5X12	1	
F08-28	6WWV-046702-5000	INNER HEX SCREW M6x12	1	
F08-29	30102-102060810	SCREW M10x1.25x60	2	
F08-30	6AQV-080005-1000-M2	REAR RPM SENSOR	1	
F08-31	6AQV-081003-1000	WIRE CLIP, REAR SPEED SENSOR	1	
F08-32	6L30-080006	WIRE CLIP 2, BRAKE FLUID HOSE	1	

NO.	CODE	EN DESCRIPTION	QTY	REMARKS
F08-33	6WWV-046802-5000	INNER HEX SCREW M6×16	1	
F08-34	6AQV-080300-1000-0VR00	REAR BRAKE FOOT PEDAL ASSY (MERCURY SILVER)	1	
F08-35	30121-080025160	SCREW M8X25	1	
F08-36	6AQV-080400-1000	SPRING	1	
F08-37	30006-060022810	BOLT M6X22	2	
F08-38	6NTG-080009	REAR GEAR RING	1	
F08-39	6AQV-080006-1000	REAR BRAKE DISC	1	
F08-40	6AQV-081000-4000-10	ABS BRAKE ASSY	1	
F08-41	8010-150003	TIE 5X250	5	

转向系统/STEERING SYSTEM

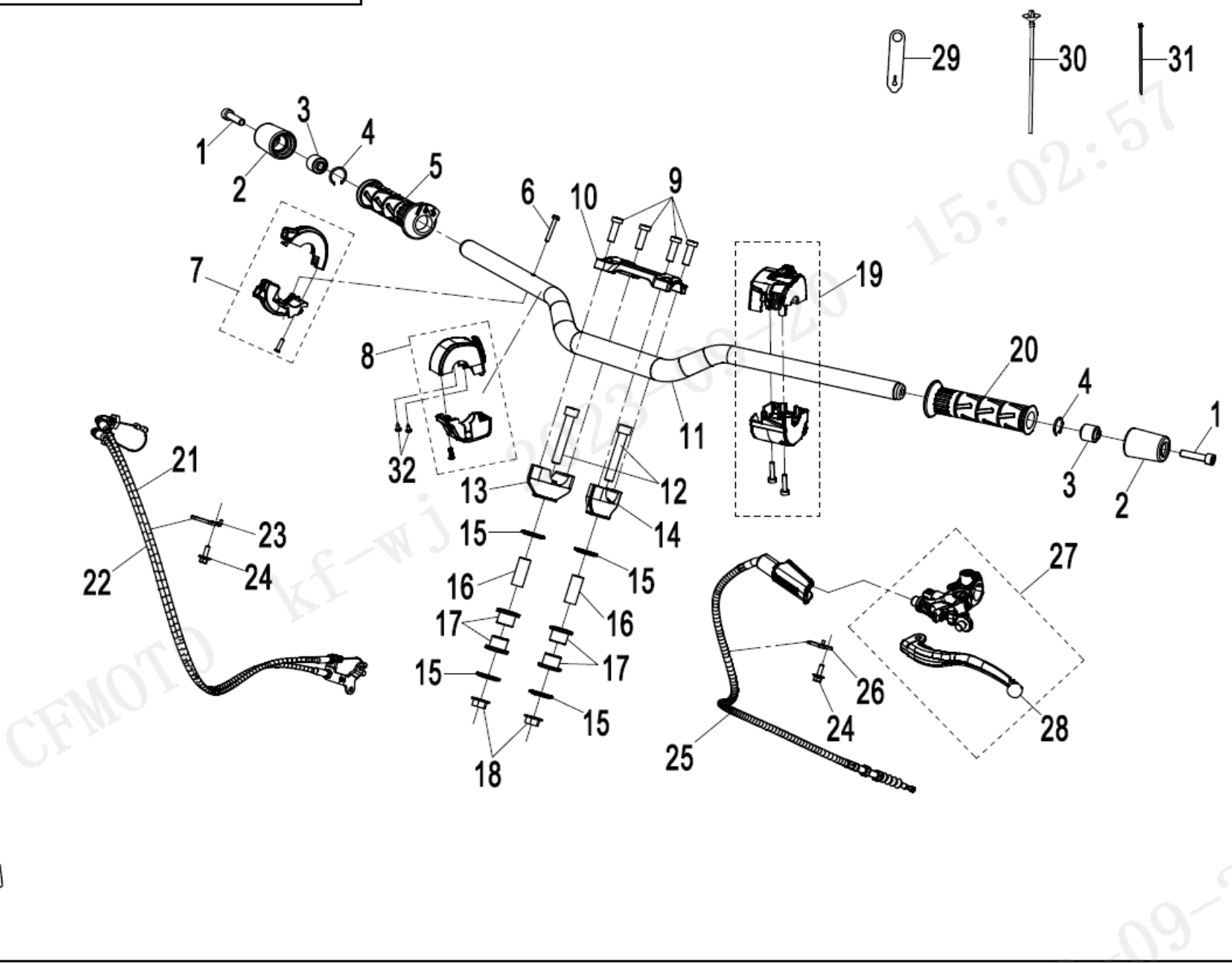

NO.	CODE	EN DESCRIPTION	QTY	REMARKS
F10-01	30102-080035810	SCREW M8X35	2	
F10-02	6NT1-100301	BALANCER	2	
F10-03	6NT1-100310	BUSHING, BALANCER	2	
F10-04	30805-02005	CIRCLIP 20	2	
F10-05	A000-100010-20000	RH HAND GRIP ASSY	1	
F10-06	30105-040030410	SCREW M4X30	1	
F10-07	6AQV-100700-1003	THROTTLE LEVER	1	
F10-08	6KMV-167000-3000	RH HANDLEBAR SWITCH ASSY	1	
F10-09	6WWV-050009-5000	SCREW M8x25	4	
F10-10	6AQV-100003-4001-0VR00	HANDLEBAR PRESS COVER (ELECTRO SILVER)	1	
F10-11	6AQV-100100-4001	HANDLEBAR ASSY	1	
F10-12	30102-102060810	SCREW M10x1.25x60	2	
F10-13	6AQV-100050-4001-0VR00	HANDLEBAR RH BRACKET (ELECTRO SILVER)	1	
F10-14	6AQV-100040-4001-0VR00	HANDLEBAR LH BRACKET (ELECTRO SILVER)	1	
F10-15	6KJ0-050005	WASHER	4	
F10-16	6KJ0-050006-00001	LINER, UPPER TRIPLE CLAMP	2	
F10-17	6KJ0-050004	DAMPER RUBBER, UPPER TRIPLE CLAMP	4	
F10-18	30204-102810	NUT M10X1.25	2	
F10-19	6AQV-166000-4000	LH HANDLEBAR SWITCH ASSY	1	
F10-20	A000-100001-10000	LH HAND GRIP	1	
F10-21	6AQV-100400-4000	THROTTLE CABLE	1	
F10-22	6AQV-100500-4000	ADJUSTABLE THROTTLE CABLE	1	
F10-23	6AQV-100602-4001	RH CABLE HOOK, HANDLEBAR	1	
F10-24	30006-050014810	BOLT M5X14	2	
F10-25	6AQV-100600-1002	CLUTCH CABLE	1	ALT:- 6AQV-100600-1001
F10-26	6AQV-100601-4001	LH CABLE HOOK, HANDLEBAR	1	
F10-27	6WWV-100200-5003	CLUTCH LEVER ASSY	1	
F10-28	6WWV-100201-5000	CLUTCH LEVER	1	
F10-29	6KJ0-100002	CLUTCH PULL BINDING	2	
F10-30	801F-100101	TIE BAND	1	
F10-31	8010-150003	TIE 5X250	2	
F10-32	30137-250120010	SCREW ST2.5X12	2	

后轮/REAR WHEEL

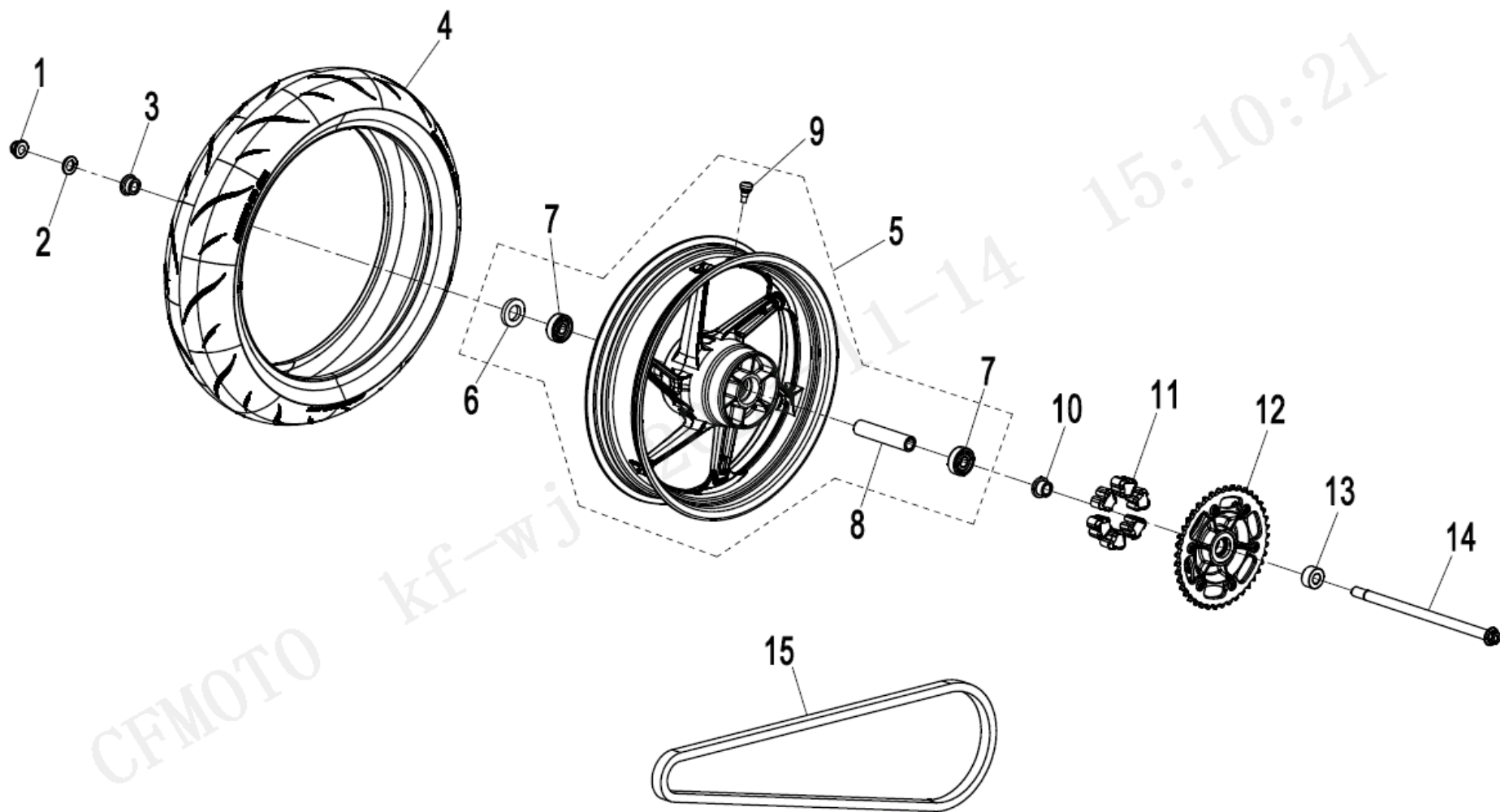

NO.	CODE	EN DESCRIPTION	QTY	REMARKS
F11-01	6AQV-060006-1000-M1	NUT	1	
F11-02	6AQV-110006-1000	WASHER, REAR WHEEL AXLE	1	
F11-03	6AQV-110004-1000	REAR WHEEL RH SHAFT BUSHING	1	
F11-04	30705SH-177600	TIRE	1	
F11-05	6AQV-110200-1001-M1-0BV00	REAR RIM ASSY	1	
F11-06	30500-027800N	OIL SEAL	1	
F11-07	30400-01784	BEARING	2	
F11-08	6AQV-110202-1000-M1	MIDDLE SPACER, REAR RIM	1	
F11-09	5190-070030-1000	VALVE, INFLATION	1	
F11-10	6AQV-110005-1000	SHAFT BUSHING, SPROCKET SEAT	1	
F11-11	6L30-110003	DAMPER, SPROCKET	6	
F11-12	6AQV-110300-1003	SPROCKET SEAT ASSY	1	
F11-13	6AQV-110003-1000	REAR WHEEL LH SHAFT BUSHING	1	
F11-14	6AQV-110007-1000	REAR WHEEL SHAFT	1	
F11-15	3120941	CHAIN	1	

油箱/FUEL TANK

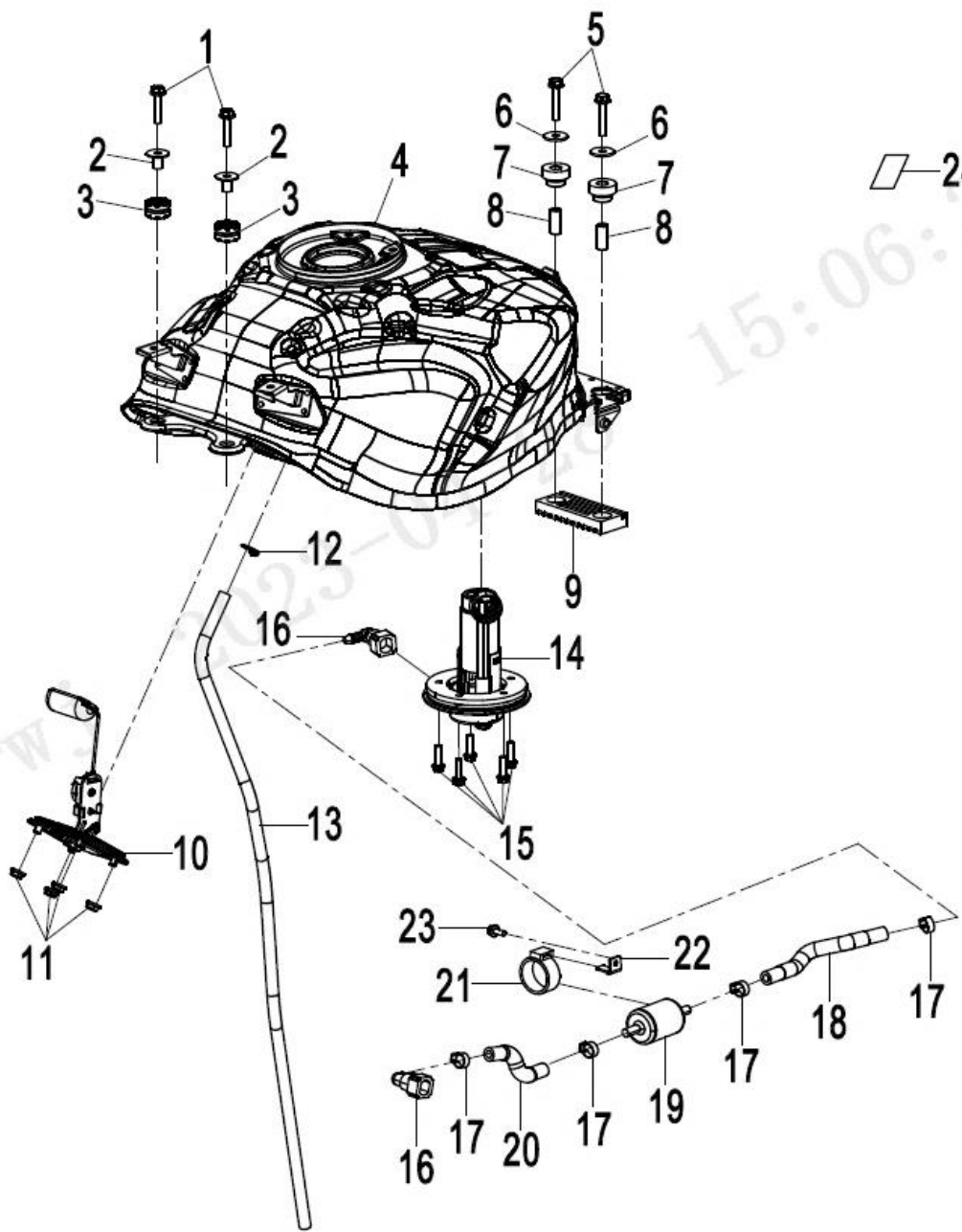

15:06:34

04-28

NO.	CODE	EN DESCRIPTION	QTY	REMARKS
F12-01	30006-060025810	BOLT	2	
F12-02	5020-031002	RUBBER SLEEVE LINER, FRONT LICENSE BRACKET	2	
F12-03	5020-031001	RUBBER SLEEVE, FRONT LICENSE BRACKET	2	
F12-04	6AQV-121000-4000	FUEL TANK ASSY	1	
F12-05	30006-060035810	BOLT	2	
F12-06	30301-060412	WAHSER	2	
F12-07	6NQ#-120004-6000	RUBBER DAMPER	2	
F12-08	6NQ#-120002-6000	BUSHING	2	
F12-09	6NQ#-120003-6000	RUBBER DAMPER BLOCK	1	
F12-10	6AQV-170200-4000-M1	FUEL LEVEL SENSOR	1	
F12-11	30204-060810	NUT	4	ALT:- 30202-060110
F12-12	30601-111010	CLAMP	1	
F12-13	6NQ0-120001	FUEL PIPE, FUEL TANK	1	
F12-14	6AQV-150900-4001-10	FUEL PUMP ASSY	1	
F12-15	30006-050020810	BOLT	5	
F12-16	6090-120210	QUICK JOINT	2	
F12-17	6070-120400	CLAMP	4	
F12-18	6AQV-120010-1000	HIGH-PRESSURE FUEL HOSE 1	1	
F12-19	805A-120004	FUEL FILTER, EFI	1	
F12-20	6AQV-120020-1000	HIGH-PRESSURE FUEL HOSE 2	1	
F12-21	6090-120221	RUBBER SLEEVE, FUEL FILTER, EFI	1	
F12-22	6AQV-120001-1000	BRACKET, FUEL FILTER	1	
F12-23	30006-050012810	BOLT	1	
F12-24	6NQ0-190005	TAPE	2	

F13座垫/SEAT

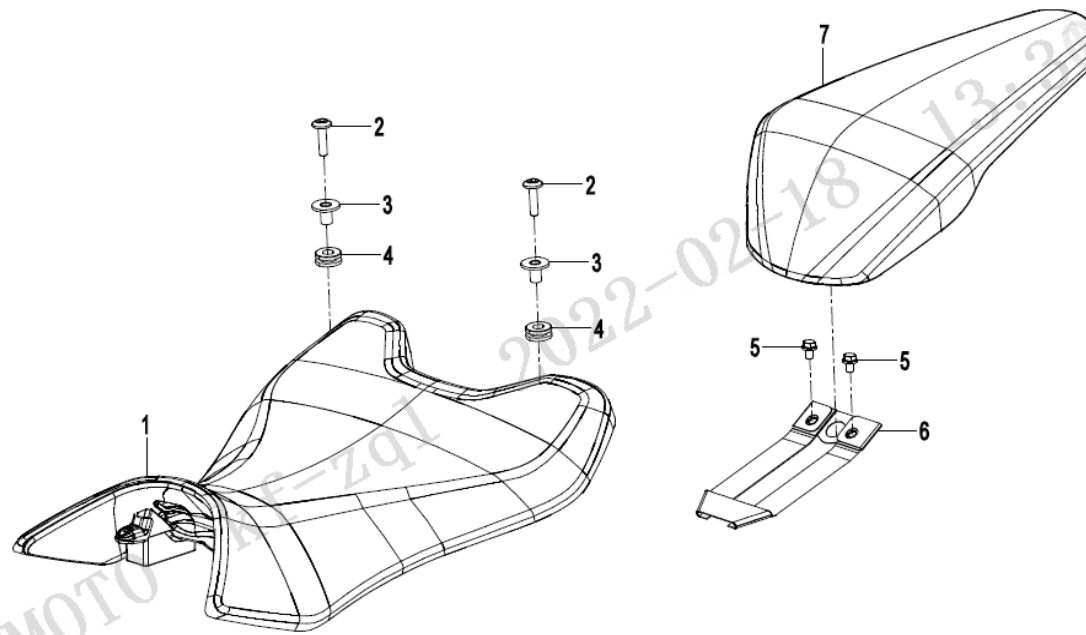

NO.	CODE	EN DESCRIPTION	QTY	REMARKS
F13-01	6AQV-130100-4000	FRONT SEAT ASSY	1	
F13-02	6GU#-000201-6000	INNER HEX SCREW M6x25	2	
F13-03	6KM0-120010	T-TYPE BUSHING ASSY	2	
F13-04	6090-040302	CUSHION SLEEVE	2	
F13-05	30006-060022810	BOLT M6X22	2	
F13-06	6AQV-130210-1000	TIE-BAND KIT	1	
F13-07	6AQV-130200-1001	REAR SEAT	1	

脚蹬/FOOTREST

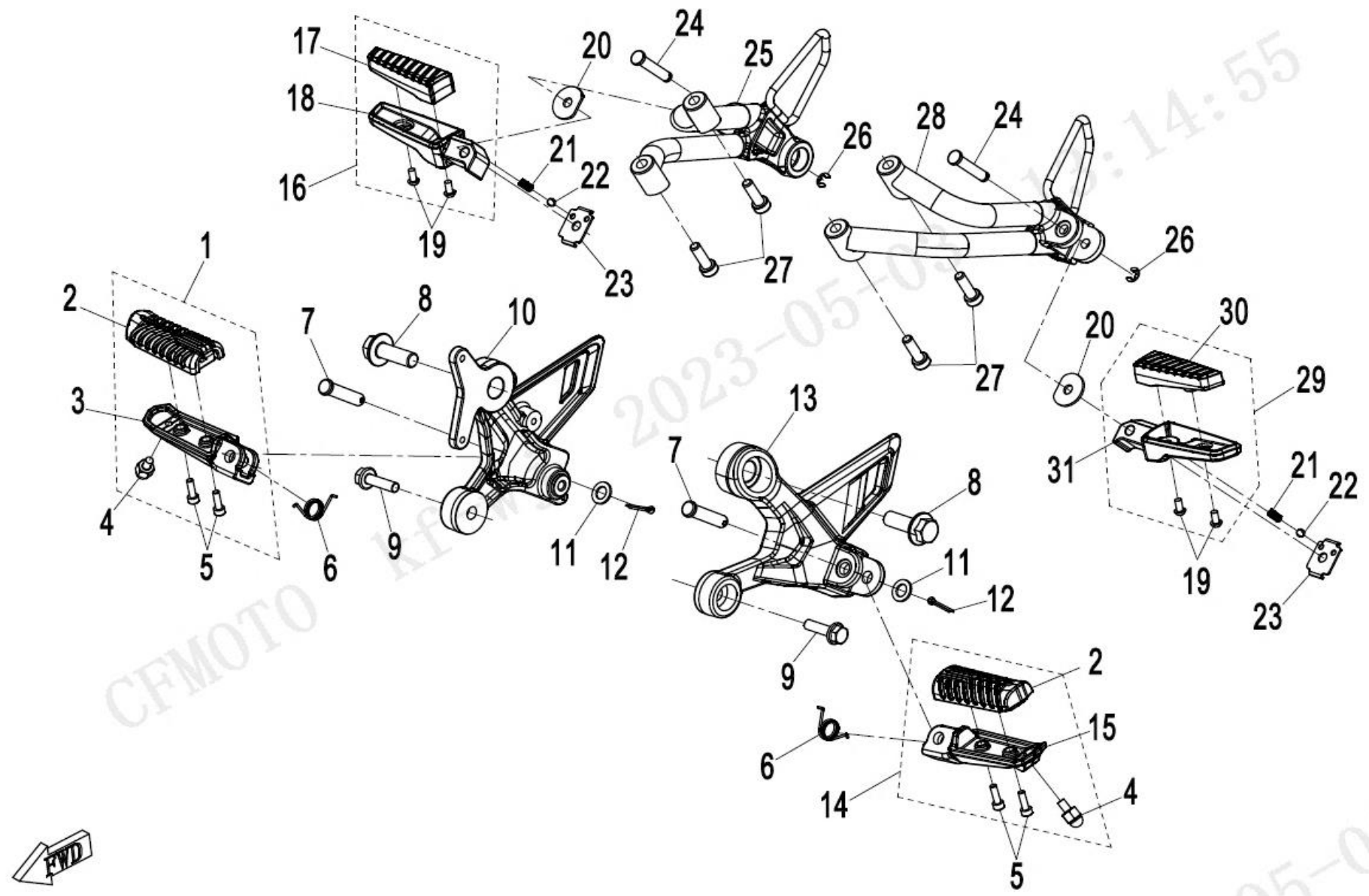

NO.	CODE	EN DESCRIPTION	QTY	REMARKS
F14-01	6KWV-140500-1000-OVR00	BRACKET ASSY, RH FRONT FOOTREST (ELECTRO SILVER)	1	
F14-02	6KMV-140170-8100	FOOTREST RUBBER	2	
F14-03	6KWV-140141-1000	FRONT RH FOOTREST SEAT	1	
F14-04	6KM0-130123	BOLT	2	
F14-05	30105-050014410	SCREW M5X14	4	
F14-06	A000-140103-20000	SPRING	2	ALT:- A000-140103-10000
F14-07	6WWV-140141-5000	PIN SHAFT	2	
F14-08	0800-014009-00002	BOLT	2	
F14-09	30006-080030810	BOLT M8X30	2	
F14-10	6AQV-140700-4001-OVR00	BRACKET, RH FRONT FOOTREST(ELECTRO SILVER)	1	
F14-11	30300-100112	WASHER 10	2	
F14-12	30903-0322210	COTTER PIN 3.2X22	2	
F14-13	6AQV-140600-4000-OVR00	LH FRONT FOOTREST BRACKET (ELECTRO SILVER)	1	
F14-14	6KWV-140400-1000-OVR00	BRACKET ASSY, LH FRONT FOOTREST (ELECTRO SILVER)	1	
F14-15	6KWV-140131-1000	FRONT LH FOOTREST SEAT	1	
F14-16	6KJV-140160-8000-0BP00	REAR RH FOOTREST ASSY	1	
F14-17	6KJ0-140142	RUBBER ASSY, RH FOOTREST	1	
F14-18	6KJV-140161-8000-0BP00	REAR RH FOOTREST SEAT (MAUD SPIRIT BLACK)	1	
F14-19	30105-050014470	SCREW M5X14	4	
F14-20	A000-140106	LOCATING GASKET 2	2	
F14-21	5190-037813	SPRING	2	
F14-22	5190-037814	STEEL BALL	2	
F14-23	A000-140104	LOCATING GASKET 1	2	
F14-24	A000-140142	PIN SHAFT Dia 8	2	
F14-25	6AQV-140040-4000-0BP00	RH REAR FOOTREST BRACKET ASSY (MAUD SPIRIT BLACK)	1	
F14-26	30802-00603	CIRCLIP 6	2	ALT:- 30802-00605
F14-27	30102-080025810	SCREW M8X25	4	
F14-28	6AQV-140030-4000-0BP00	LH REAR FOOTREST BRACKET ASSY (MAUD SPIRIT BLACK)	1	
F14-29	6KJV-140150-8000-0BP00	REAR LH FOOTREST ASSY	1	
F14-30	6KJ0-140132	RUBBER, LH FOOT PEDAL	1	
F14-31	6KJV-140151-8000-0BP00	REAR LH FOOTREST SEAT (MAUD SPIRIT BLACK)	1	

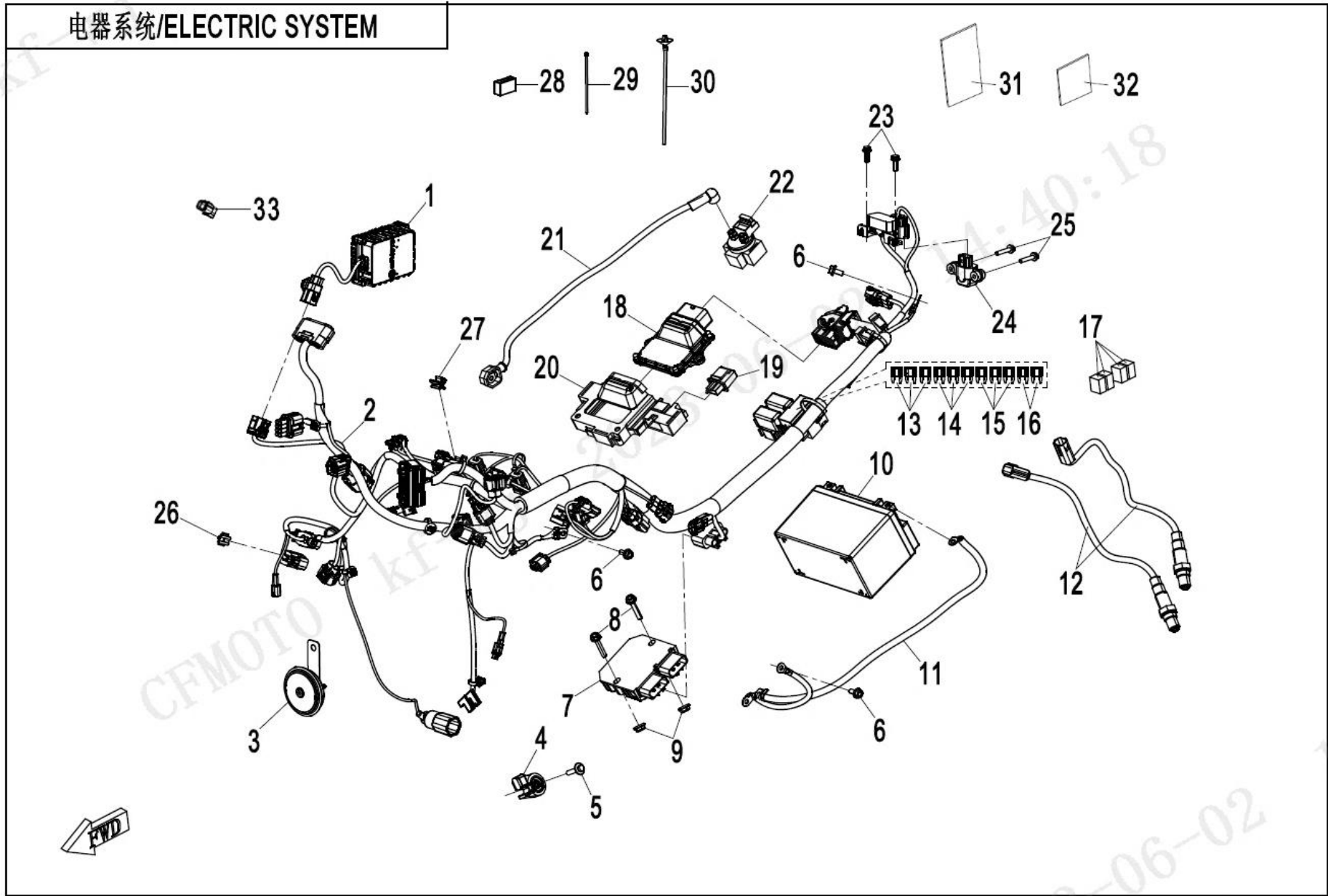

NO.	CODE	EN DESCRIPTION	QTY	REMARKS
F15-01	SN1V-691100-1201-11	T-BOX	1	
F15-02	6AQV-150100-4001	MAIN CABLE	1	

NO.	CODE	EN DESCRIPTION	QTY	REMARKS
F15-03	6FIV-150600-7000	HORN	1	
F15-04	6KMV-151500-3000	SIDE STAND SWITCH	1	
F15-05	8010-090005	BOLT M6x16	1	
F15-06	30006-060012810	BOLT M6X12	3	ALT:- 30006-060012870
F15-07	6NTV-151000-3000	REGULATOR	1	
F15-08	30006-060025810	BOLT M6X25	2	
F15-09	30204-060810	NUT M6	2	ALT:- 30202-060110
F15-10	83200-0000-750006	BATTERY 12V12AH	1	
F15-11	6AQV-150420-1001	NEGATIVE CABLE, BATTERY	1	
F15-12	0HU0-176000	OXYGEN SENSOR	2	
F15-13	8010-151301	FUSE 5A	3	
F15-14	806A-151302	FUSE 10A	3	
F15-15	806A-151305	FUSE 15A	3	
F15-16	806A-151307	25A FUSE	2	
F15-17	5BY4-150330	AUXILIARY RELAY	4	
F15-18	6AQV-001000-4000	ECU ASSY	1	
F15-19	6FIA-150340-6400	FLASHER	1	
F15-20	6AQV-001300-1000	ECU RUBBER	1	
F15-21	6AQV-150310-1000	POSITIVE CABLE, STARTER MOTOR	1	
F15-22	9CR6-150310	STARTER RELAY	1	
F15-23	0010-030002-00001	BOLT	2	
F15-24	6KJ0-150600	SENSOR, ROLL-OVER	1	
F15-25	30006-050020810	BOLT M5X20	2	
F15-26	CFCV-CBC005-2000-M1	CLIP	1	
F15-27	6AQV-150001-1000-M1	CLIP	1	
F15-28	6100-150500	RUBBER SLEEVE, FLASHER	2	
F15-29	8010-150003	TIE	19	
F15-30	801F-100101	TIE BAND	2	
F15-31	5270-150001	BATTERY FOAM MAT LH AND RH	2	
F15-32	5270-150002	FOAM (FR &RR), BATTERY	1	
F15-33	CFCV-156103-2000	T-BOX CONNECTOR PLUG	1	

灯具/LIGHTS

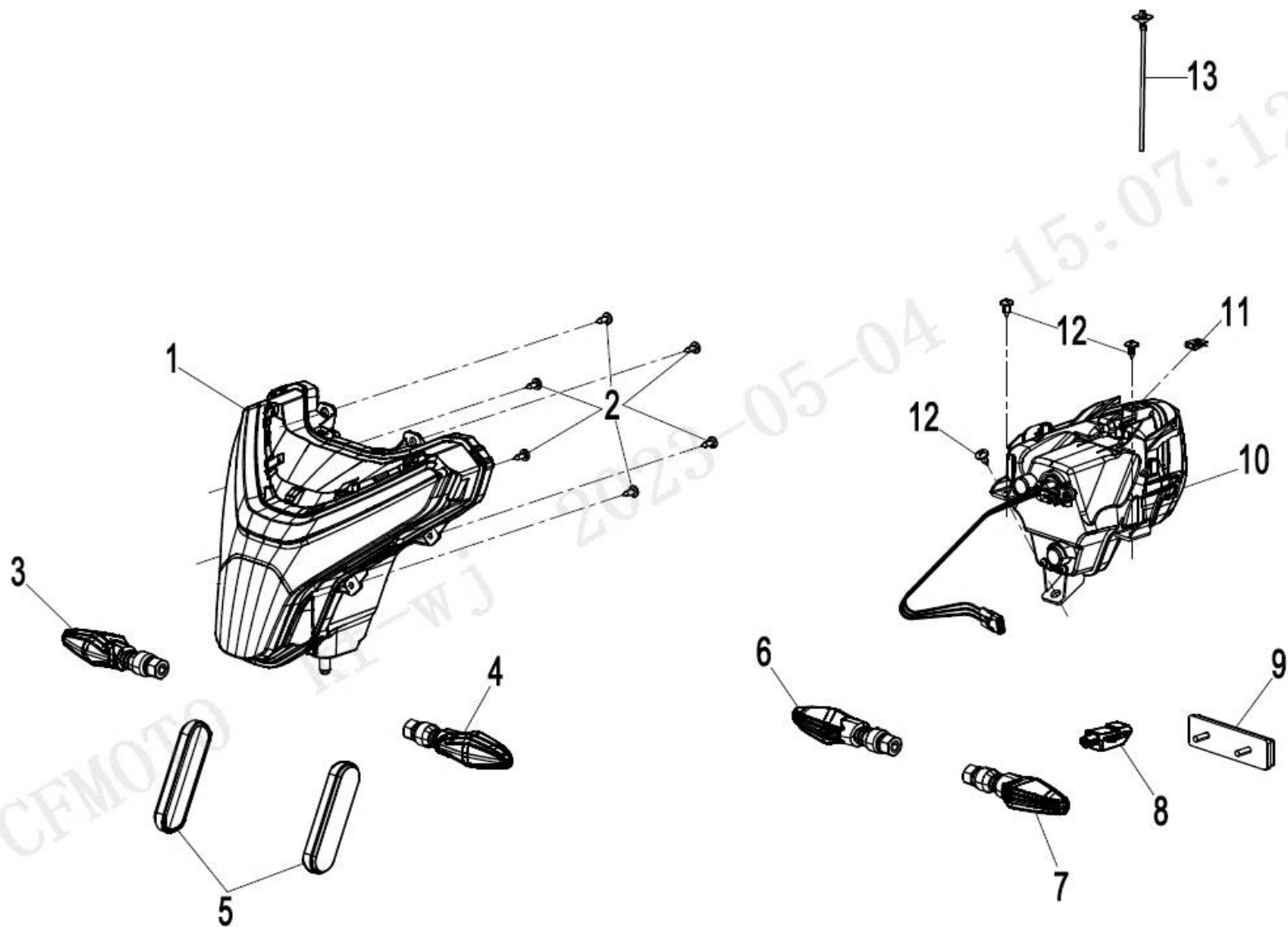

NO.	CODE	EN DESCRIPTION	QTY	REMARKS
F16-01	6AQV-160100-4001	HEADLIGHT	1	
F16-02	30110-420130070	SELF-TAPPING SCREW ST 4.2X13	6	
F16-03	6KJC-163200-8000	FRONT RH TURN LIGHT	1	
F16-04	6KJC-163100-8000	FRONT LH TURN LIGHT	1	
F16-05	6KJV-160920-8001-M1	FRONT SIDE REFLECTOR	2	ALT:- 6KJ0-050030
F16-06	6KM0-160500-00004	FRONT RH TURN LIGHT	1	
F16-07	6KM0-160400-00004	FRONT TURN LIGHT, LH	1	
F16-08	6FIV-160600-6601	LICENSE LIGHT	1	
F16-09	6KM0-160230-00001	REAR REFLECTOR	1	ALT:- 6KM0-160230
F16-10	6AQV-160200-1003	TAIL LIGHT	1	
F16-11	8080-000002	CLIP NUT ST4.8	1	
F16-12	30110-481130070	SELF-TAPPING SCREW	3	
F16-13	801F-100101	TIE BAND	2	

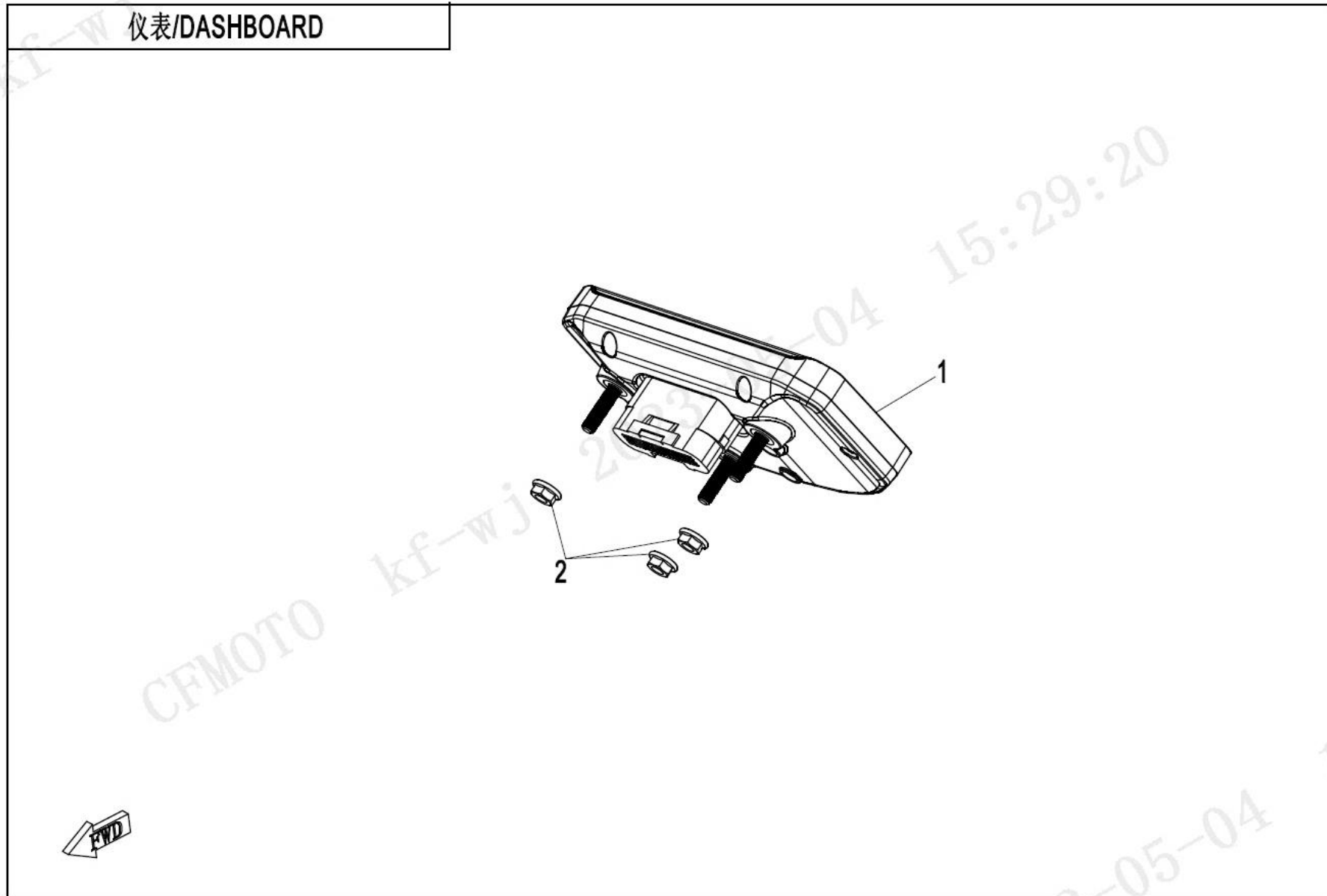

NO.	CODE	EN DESCRIPTION	QTY	REMARKS
F17-01	6AQV-171000-5100	LCD DASHBOARD	1	
F17-02	30204-060810	NUT	3	ALT:- 30202-060110

冷却系统/COOLING SYSTEM

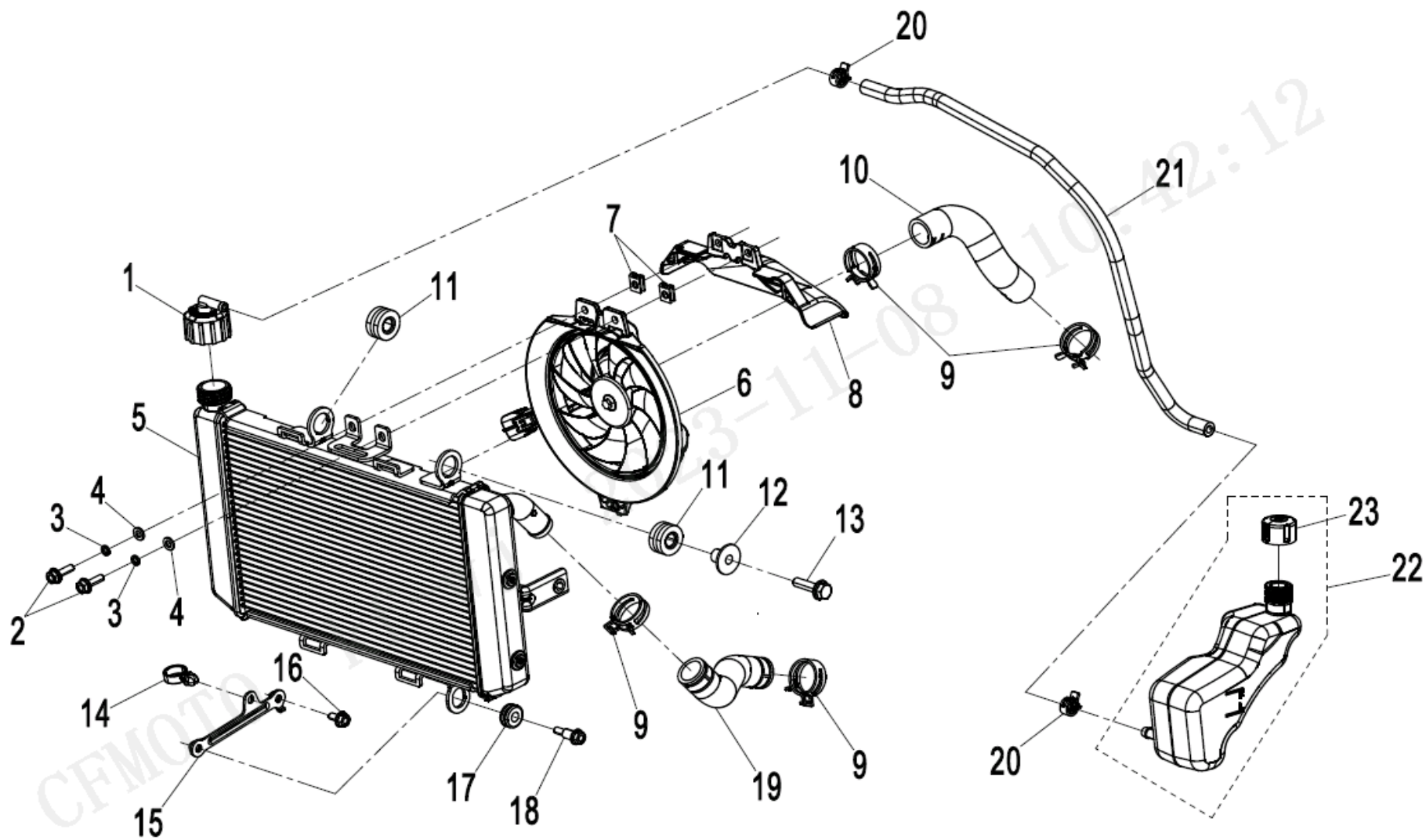

1/2/3/4/5/6/7/8/17

24



NO.	CODE	EN DESCRIPTION	QTY	REMARKS
F18-01	6GUV-181010-6001	FILLER CAP ASSY	1	
F18-02	30006-060020870	BOLT M6X20	2	ALT:- 30006-060020810
F18-03	30303-060112	WASHER 6	2	ALT:- 30303-060152
F18-04	30306-060142	WASHER	2	
F18-05	6AQV-181100-4000	RADIATOR ASSY	1	
F18-06	6AQV-181200-1000	FAN MOTOR	1	
F18-07	8030-040800-00001	NUT CLIP M6	2	
F18-08	6AQV-181000-1000-20	DEFLECTOR	1	
F18-09	30601-229060	CLAMP	4	
F18-10	6AQV-180002-1000	RADIATOR WATER OUTLET HOSE	1	
F18-11	A000-180005	RADIATOR SHOCK ABSORBER RUBBER 2	2	
F18-12	A000-180010-20000	RADIATOR RUBBER DAMPER 2 BUSHING	1	
F18-13	30006-080030870	BOLT M8X30	1	
F18-14	A000-050015	WIRE CLIP, FRONT BRAKE FLUID HOSE	1	
F18-15	6AQV-180010-4000	CONNECTING BRACKET ASSY	1	
F18-16	30006-060012870	BOLT M6X12	1	ALT:- 30006-060012810
F18-17	6WWV-181001-5000	DAMPING MAT, RADIATOR	1	
F18-18	6WWV-180008-5000	BOLT M6X25	1	
F18-19	6AQV-180001-1000	RADIATOR WATER INLET HOSE	1	
F18-20	30601-212570	CLAMP	2	
F18-21	6AQV-180003-4000	CONNECTING PIPE, RESERVOIR TANK	1	
F18-22	6AQV-180100-4000	RESERVOIR ASSY	1	
F18-23	6AQV-180110-4000	RESERVOIR CAP ASSY	1	
F18-24	6AQV-181000-4000	RADIATOR FAN ASSY	1	



NO.	CODE	EN DESCRIPTION	QTY	REMARKS
F19-1-01	6NQ#-190002-6002	SAFETY WARNING INSTRUCTION LABEL	1	ALT:- A000-190102
F19-1-02	6AQV-190002-5000	SAFETY BELT LABEL	1	
F19-1-03	6AQV-190006-4000-10	MODEL DECAL	2	
F19-1-04	9GQA-190201-10000	WARNING LABEL, FUEL FILLING PORT	1	

星光白配色

岩石银黑
 骑士黑
 星光白
 荧光玫红色
 蓝宝石黑
 电镀银
 深空灰

刀模线(半模线)
 覆膜线(定位线)

光白亮光
 光白哑光

透明亮光
 透明哑光

光白材料, 亚光光油 (贴轮辋)

1. 工件: 左右侧 前/后轮辋 亚光面 x4

2. 工件: 左右侧 前/后轮辋 亚光面 x4

透明材料, 亚光光油

6. 工件: 油箱左前装饰板亚光面

7. 工件: 油箱右前装饰板亚光面

8. 工件: 前挡泥板亚光面 x2

9. 工件: 散热器左/右外装饰板 亚光面 x2

透明材料, 亮光光油

3. 工件: 尾灯左尾罩 亮光面

4. 工件: 尾灯右尾罩 亮光面

5. 工件: 前挡泥装饰板 亮光面

光白材料, 亮光光油

10. 工件: 散热器左内装板装饰条 亮光面

11. 工件: 散热器右内装板装饰条 亮光面

特殊要求: 定位板没到Line

NO.	CODE	EN DESCRIPTION	QTY	REMARKS
F19-A-01	6AQV-190107-4000-11	RIM DECAL 1	4	
F19-A-02	6AQV-190111-4000-11	RIM DECAL 2	4	
F19-A-03	6AQV-190101-4000-11	TAILLIGHT LH GUARD DECAL	1	
F19-A-04	6AQV-190102-4000-11	TAILLIGHT RH GUARD DECAL	1	
F19-A-05	6KWV-190106-1000-10	FRONT FENDER DECO PLATE DECAL	1	
F19-A-06	6AQV-190103-4000-11	FUEL TANK LH FRONT DECO PLATE DECAL	1	
F19-A-07	6AQV-190104-4000-11	FUEL TANK RH FRONT DECO PLATE DECAL	1	
F19-A-08	6KWV-190107-1000-11	ABS DECAL	2	
F19-A-09	6AQV-190112-4001-10	CFMOTO DECAL	2	
F19-A-10	6AQV-190105-4002-11	RADIATOR LH DECO PLATE DECAL	1	
F19-A-11	6AQV-190106-4001-11	RADIATOR RH DECO PLATE DECAL	1	
F19-A-12	6AQV-190100-4003-11	DECAL ASSY	1	

春风蓝配色

刀模线(半模线) 覆膜线(定位线)

骑士黑 星光白 春风蓝 岩浆红 星光黑 电镀银

光白亮光 光白哑光
 透明亮光 透明哑光

1. 工件: 尾灯左尾罩 亮光面 2. 工件: 尾灯右尾罩 亮光面

3. 工件: 油箱左前装饰板 亮光面 4. 工件: 油箱右前装饰板 亮光面

5. 工件: 散热器左内装板装饰条 亮光面

6. 工件: 散热器右内装板装饰条 亮光面

7. 工件: 前挡泥装饰板 亮光面

透明材料, 亮光光油

12. 工件: 前挡泥板 亚光面

13. 工件: 散热器左/右外装饰板 亚光面

透明材料, 亚光光油

8. 工件: 左侧 前/后轮辋 亚光面 x2

10. 工件: 前/后轮辋 (左侧) 骑士黑, 亚光面

9. 工件: 右侧 前/后轮辋 亚光面 x2

11. 工件: 前/后轮辋 (右侧) 骑士黑, 亚光面

光白材料, 亚光光油 (贴轮辋)

NO.	CODE	EN DESCRIPTION	QTY	REMARKS
F19-B-01	6AQV-190101-4000-10	TAILLIGHT LH GUARD DECAL	1	
F19-B-02	6AQV-190102-4000-10	TAILLIGHT RH GUARD DECAL	1	
F19-B-03	6AQV-190103-4000-10	FUEL TANK LH FRONT DECO PLATE DECAL	1	
F19-B-04	6AQV-190104-4000-10	FUEL TANK RH FRONT DECO PLATE DECAL	1	
F19-B-05	6AQV-190105-4002-10	RADIATOR LH DECO PLATE DECAL	1	
F19-B-06	6AQV-190106-4001-10	RADIATOR RH DECO PLATE DECAL	1	
F19-B-07	6KWV-190106-1000-11	FRONT FENDER DECO PLATE DECAL	1	
F19-B-08	6AQV-190107-4000-10	RIM LH DECAL 1	2	
F19-B-09	6AQV-190108-4000-10	RIM RH DECAL 1	2	
F19-B-10	6AQV-190109-4000-10	RIM LH DECAL 2	2	
F19-B-11	6AQV-190111-4000-10	RIM RH DECAL 2	2	
F19-B-12	6KWV-190107-1000-11	ABS DECAL	2	
F19-B-13	6AQV-190112-4001-10	CFMOTO DECAL	2	
F19-B-14	6AQV-190100-4003-10	DECAL ASSY	1	

随车工具/TOOLS

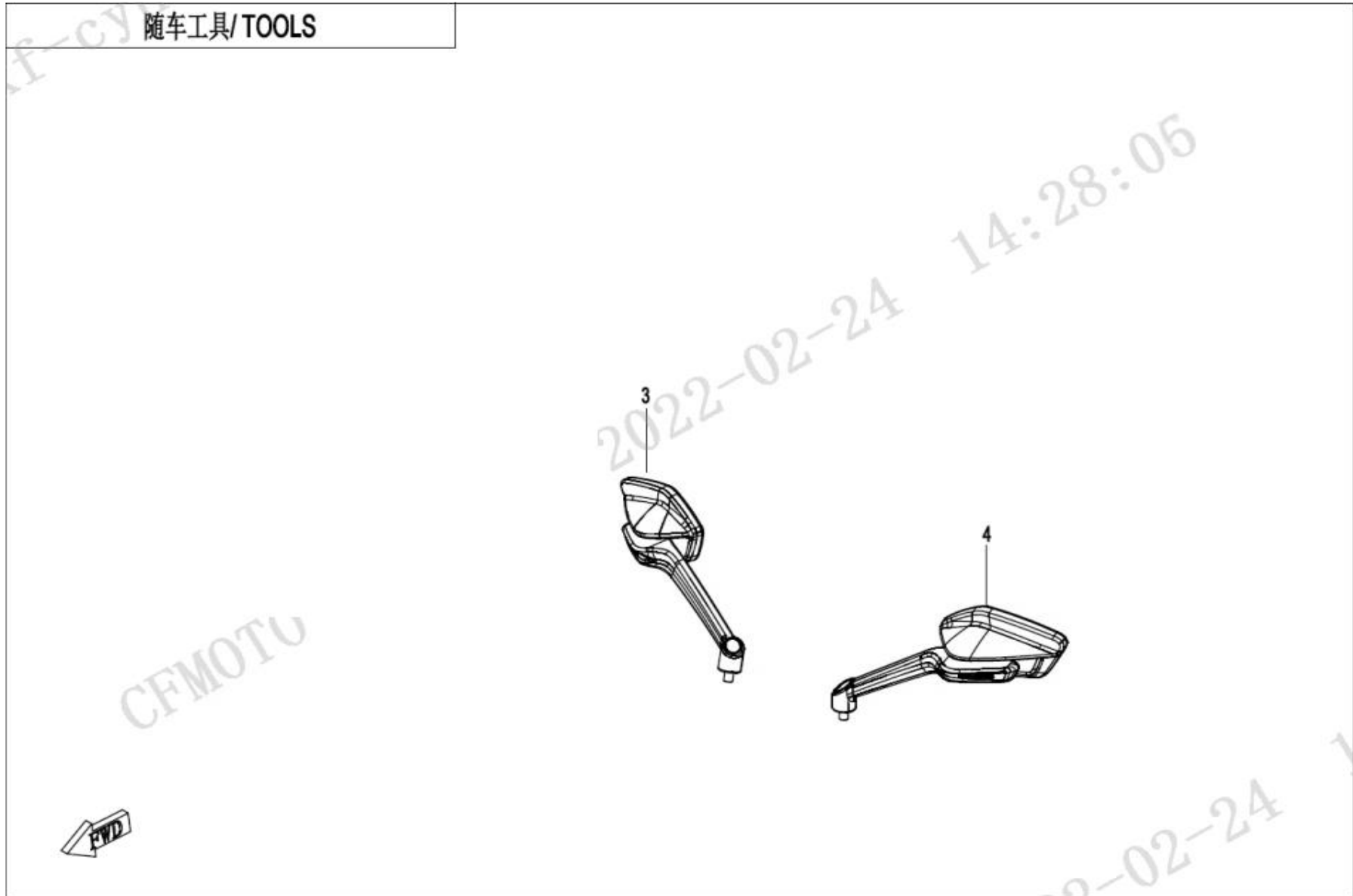

NO.	CODE	EN DESCRIPTION	QTY	REMARKS
F20-03	6AQV-200400-4002	RH REARVIEW MIRROR ASSY	1	
F20-04	6AQV-200300-4002	LH REARVIEW MIRROR ASSY	1	

燃油蒸发系统/FUEL VAPORIZAION SYSTEM

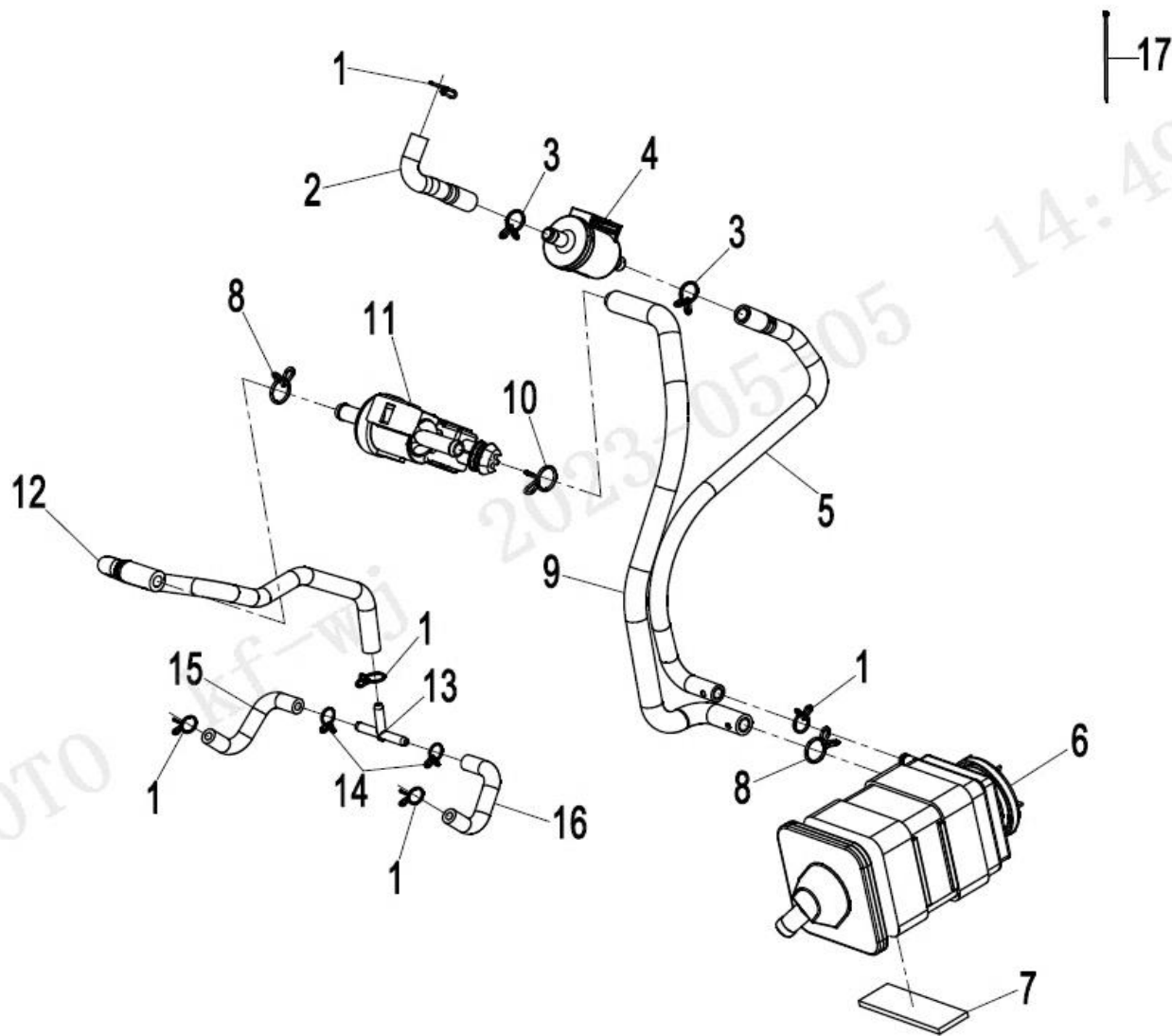

CFMOTO

2023-05-05

14:49:36

2-05-05

NO.	CODE	EN DESCRIPTION	QTY	REMARKS
F36-01	30601-109010	CLAMP A9	5	
F36-02	6AQV-360001-4000	FUEL VAPOR ADSORPTION HOSE 1	1	
F36-03	30601-110010	CLAMP A10	2	
F36-04	6WWV-360010-5000	"TWO-WAY VALVE	1	
F36-05	6AQV-360002-4000	FUEL VAPOR ADSORPTION HOSE 2	1	
F36-06	6L30-360200	CANISTER	1	
F36-07	4020-040202	SPONGE, FRONT VENTILATION PLATE	1	
F36-08	30601-111010	CLAMP A11	2	
F36-09	6AQV-360003-4000	FUEL VAPOR DESORPTION HOSE 1	1	
F36-10	30601-112010	CLAMP A12	1	
F36-11	1F30-172000	CANISTER MAGNETIC VALVE	1	
F36-12	6AQV-360004-1000	FUEL VAPOR DESORPTION HOSE 2	1	
F36-13	8010-360001	VACUUM T-JOINT	1	
F36-14	30601-108010	CLAMP A8	2	
F36-15	6AQV-360008-1000	RH FUEL VAPOR DESORPTION HOSE	1	
F36-16	6AQV-360007-1000	LH FUEL VAPOR DESORPTION HOSE	1	
F36-17	8010-150003	TIE 5X250	2	

空滤器组/AIR FILTER ASSY

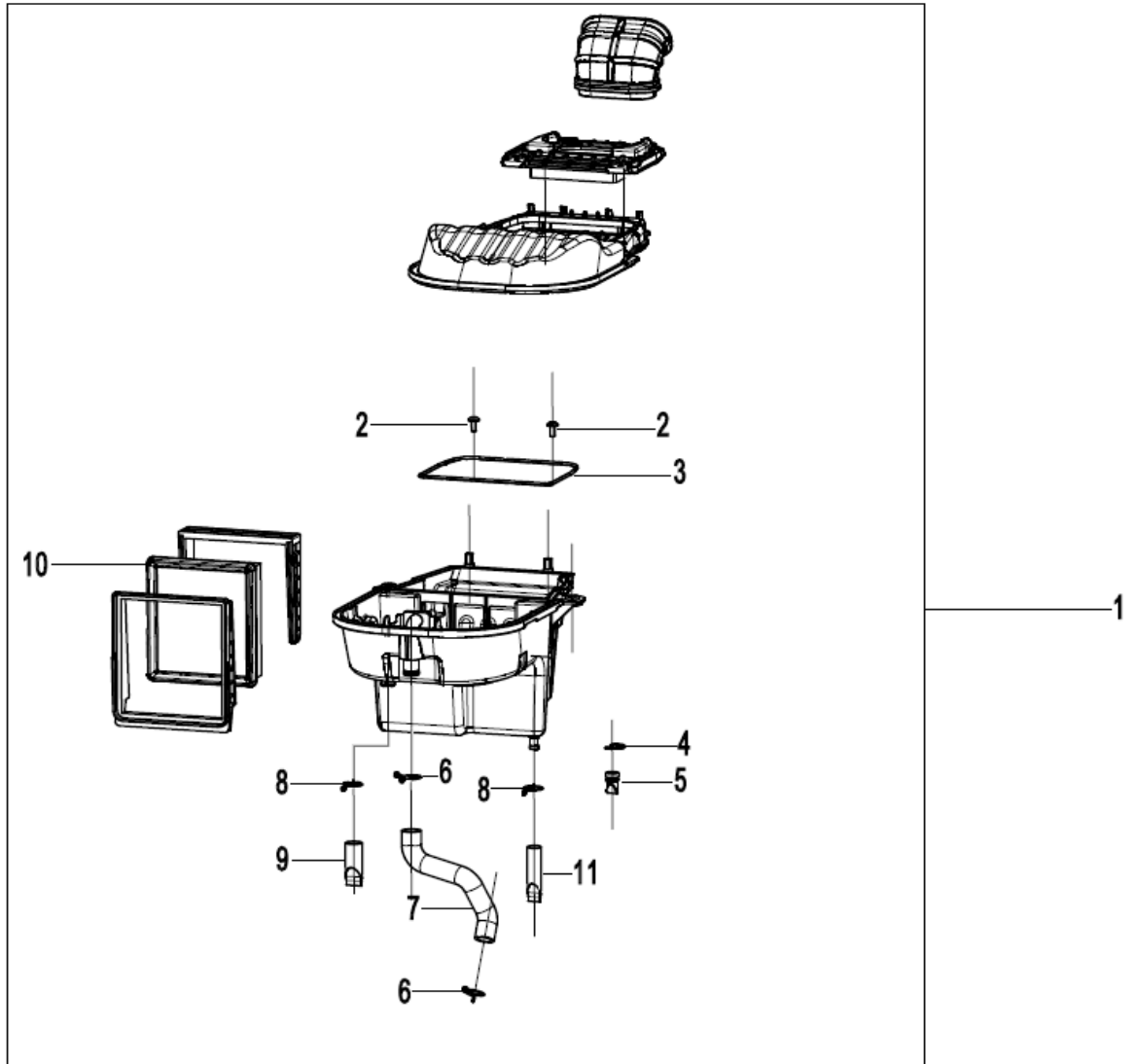

NO.	CODE	EN DESCRIPTION	QTY	REMARKS
F41-01	OSQV-110000-1001	AIR FILTER	1	
F41-02	6NTA-040202	INNER HEX SCREW M5x12	2	
F41-03	OSQV-110000-1000-20	SEAL RING	1	
F41-04	30601-111010	CLAMP A11	1	
F41-05	OSQV-110000-1000-21	VALVE	1	
F41-06	30601-118010	CLAMP A18	2	ALT:- 30601-120030
F41-07	OSQV-110008-1000	BREATHER HOSE, CRANKCASE	1	
F41-08	30601-117010	CLAMP A17	2	
F41-09	OSQV-110000-1000-24	STORAGE HOSE	1	
F41-10	OSQV-112000-1000	FILTER ELEMENT	1	
F41-11	OSQV-110000-1000-25	OIL STORAGE HOSE	1	
F41-12	0120-110003	CLAMP 52	2	

上曲轴箱分总成和下曲轴箱分总成/UPPER & LOWER CRANKCASE

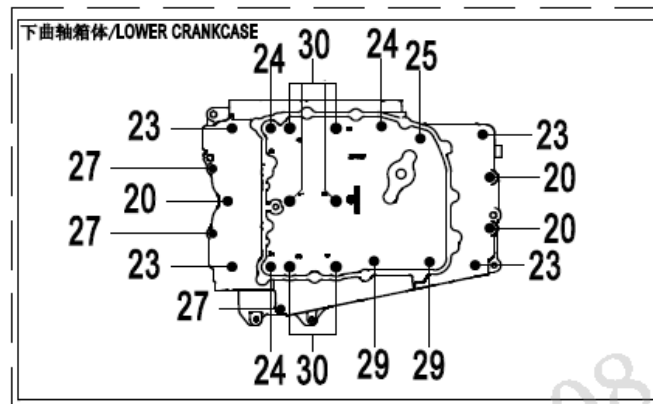
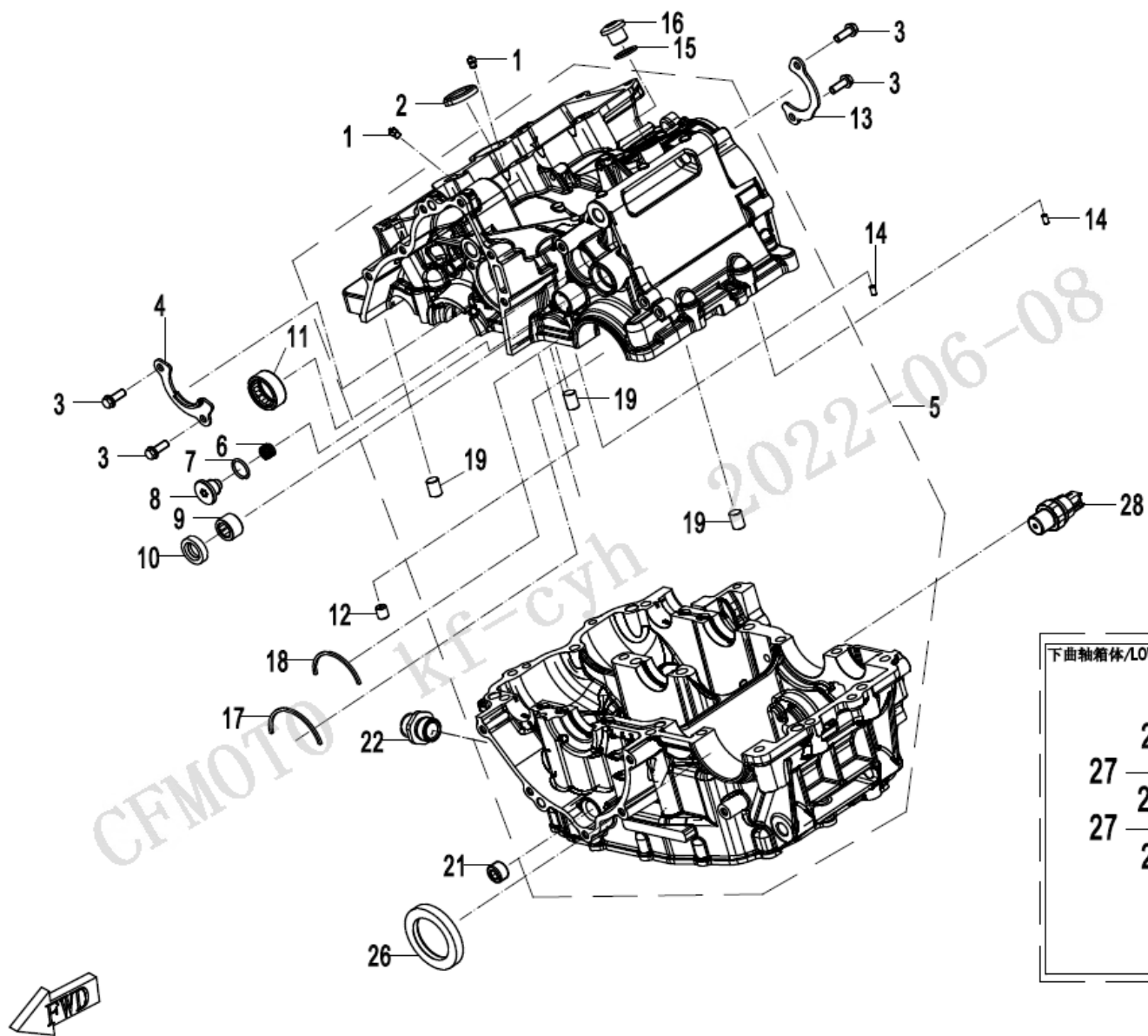

NO.	CODE	EN DESCRIPTION	QTY	REMARKS
E01-1-01	0SQV-011102-1000	OIL NOZZLE Dia 0.7	2	
E01-1-02	0SQV-011104-1000	SEAL RING, FILLER	1	
E01-1-03	0010-090005-0010	BOLT M6x16	4	
E01-1-04	0SQV-011105-1000	BEARING GUARD, LH	1	
E01-1-05	0SQV-01FZ01-1003-0BP00	CRANKCASE ASSY	1	
E01-1-06	0SQV-060011-1000	BEARING SLEEVE	2	
E01-1-07	0SQV-011107-1000	O-RING 15X1.9	1	
E01-1-08	0SQV-011108-1000	FORK SHAFT COVER	1	
E01-1-09	30403-01400	NEEDLE BEARING	1	
E01-1-10	1F30-011600	OIL SEAL 14X24X6	1	
E01-1-11	30403-02500	BEARING	1	
E01-1-12	0SQV-011103-1000	RESTRICTION PLUG	1	
E01-1-13	0SQV-011106-1000	BEARING GUARD, RH	1	
E01-1-14	30406-00401	ROLLER NEEDLE P4x7.8	2	ALT:- 920301-40078-PG2
E01-1-15	0180-011006	GASKET 14	1	
E01-1-16	0180-021008-00001	BOLT M14X1.25X12	1	
E01-1-17	0SQV-011004-1000	RETAINER, BEARING	1	
E01-1-18	0SQV-011003-1000	RETAINER, BEARING	1	
E01-1-19	30410-01000	ROLLER 10x14	3	
E01-1-20	0SQV-012003-1000	BOLT M8x45	3	
E01-1-21	0700-012105-00001	PLUG, MAIN OIL RAIL	1	
E01-1-22	0700-012106-00002	OIL FILTER BOLT	1	
E01-1-23	0SQV-012002-1000	BOLT M8x65	4	
E01-1-24	0SQV-012500-1000	BOLT ASSY M8X105	3	
E01-1-25	0SQV-012600-1000	BOLT ASSY M8X55	1	
E01-1-26	0SQV-010001-1001	COUNTERSHAFT OIL SEAL 40X58X8	1	
E01-1-27	0010-060012-0010	BOLT M6x30	3	
E01-1-28	0SQV-012400-1000	OIL PRESSURE SWITCH	1	
E01-1-29	0SQV-012700-1000	BOLT ASSY M8X45	2	
E01-1-30	0SQV-012200-1000	BOLT ASSY M9X108	6	

右&左侧盖分总成/RIGHT&LEFT SIDE COVER

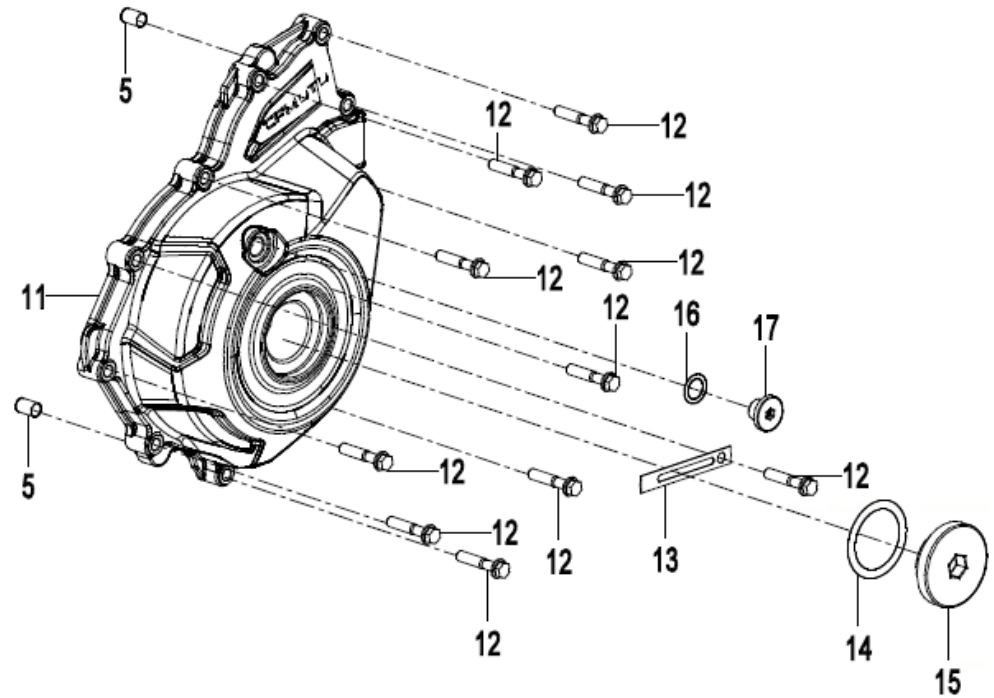
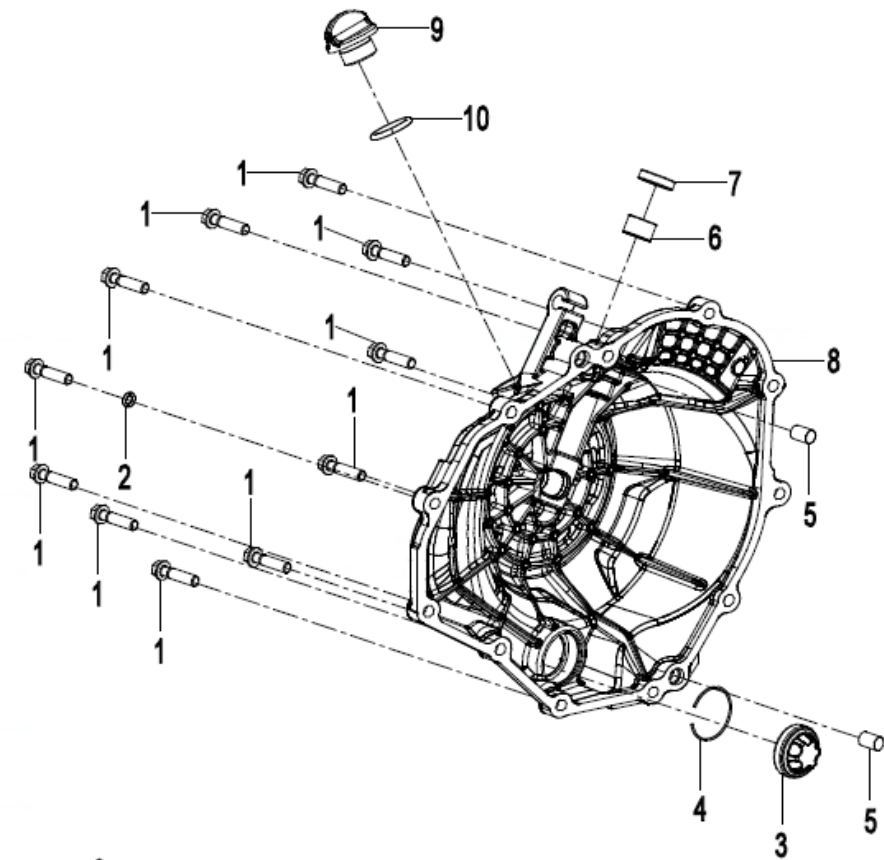

NO.	CODE	EN DESCRIPTION	QTY	REMARKS
E01-2-01	0010-021017-0010	BOLT M6x25	11	
E01-2-02	0700-012201	O-RING 5X2	1	
E01-2-03	0SQV-013100-1000-M1	VIEWER, OIL LEVEL	1	
E01-2-04	0SQV-013001-1000	CIRCLIP	1	
E01-2-05	30410-00800	ROLLER	4	
E01-2-06	30403-01200	BEARING 12X16X10	1	
E01-2-07	0010-080009	OIL SEAL 12X20X5	1	
E01-2-08	0SQV-013005-1001-0D300	RH SIDE COVER (MIST SILVER BLACK)	1	ALT:- 0SQV-013005-1000-0D300
E01-2-09	0700-013008	PLUG, OIL FILLING	1	
E01-2-10	0110-013030	O-RING 18X3.55	1	
E01-2-11	0SQV-014001-1000-0D300	LH SIDE COVER (MIST SILVER BLACK)	1	
E01-2-12	0010-060012-0010	BOLT M6x30	11	
E01-2-13	0180-014010	WIRE CLIP	1	
E01-2-14	01A0-012003	O-RING 35X3.5	1	
E01-2-15	01A0-012002-0D300	STRAINER COVER (MIST SILVER BLACK)	1	
E01-2-16	ODM0-011006	O-RING 13X2	1	
E01-2-17	ODM0-014003	VIEWING HOLE, TIMING INSPECTION	1	

油底壳分总成/OIL PAN

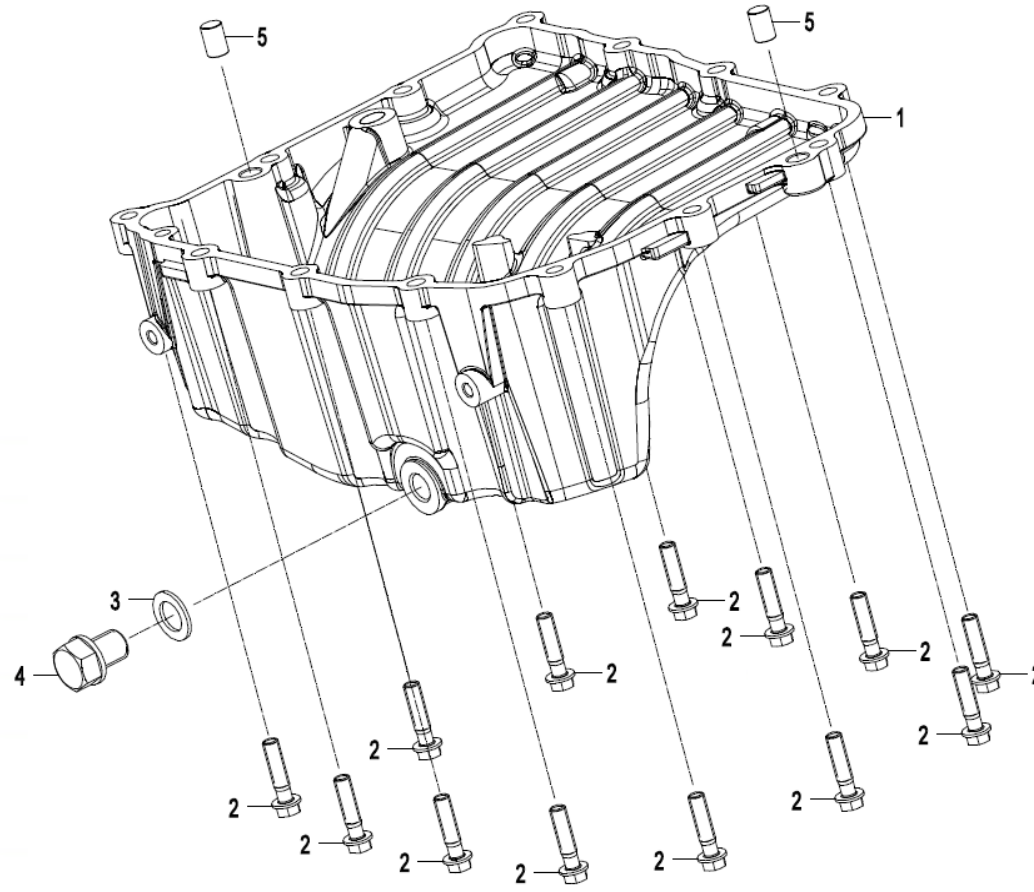

NO.	CODE	EN DESCRIPTION	QTY	REMARKS
E01-3-01	OSQV-015001-1001-OBP00	OIL PAN (MIST SILVER BLACK)	1	
E01-3-02	0010-021017-0010	BOLT M6x25	13	
E01-3-03	0010-021014	WASHER 12	1	
E01-3-04	0180-011500	MAGNETIC DRAIN BOLT M12X1.5	1	
E01-3-05	30410-00800	ROLLER	2	

气缸盖罩分总成/CYLINDER HEAD COVER

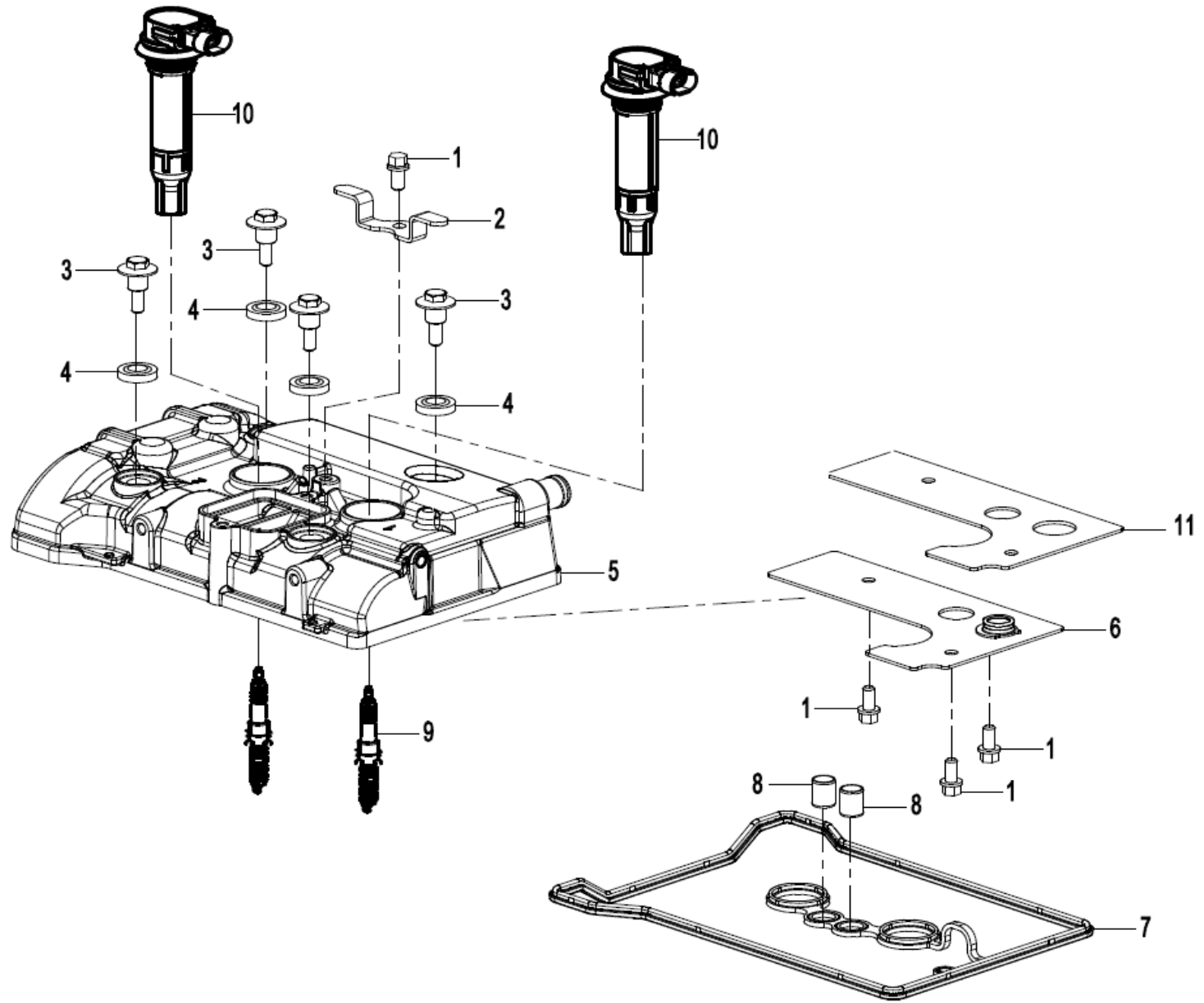

NO.	CODE	EN DESCRIPTION	QTY	REMARKS
E02-1-01	0010-021019-0010	BOLT M6x12	4	
E02-1-02	0SQV-021004-1000	PRESS PLATE	1	
E02-1-03	0700-021003-00001	CYLINDER HEAD COVER BOLT (GALVANIZED TRIVALENT CHRO)	4	
E02-1-04	0700-021200	CYLINDER HEAD COVER BOLT SEAL RING	4	
E02-1-05	0SQV-021010-1001-0BP00	CYLINDER HEAD COVER ASSY (MIST SILVER BLACK)	1	
E02-1-06	0SQV-021100-1000	PRESS PLATE	1	
E02-1-07	0SQV-021002-1000	GASKET, CYLINDER HEAD COVER	1	
E02-1-08	0HU0-021002-00001	GULP PIN	2	
E02-1-09	0SQV-170200-1000	SPARK PLUG	2	
E02-1-10	0SQV-178000-1000	IGNITION COIL	2	
E02-1-11	0SQV-021005-1000	LABYRINTH COVER GASKET	1	

气缸盖分总成(1)/CYLINDER HEAD(1)

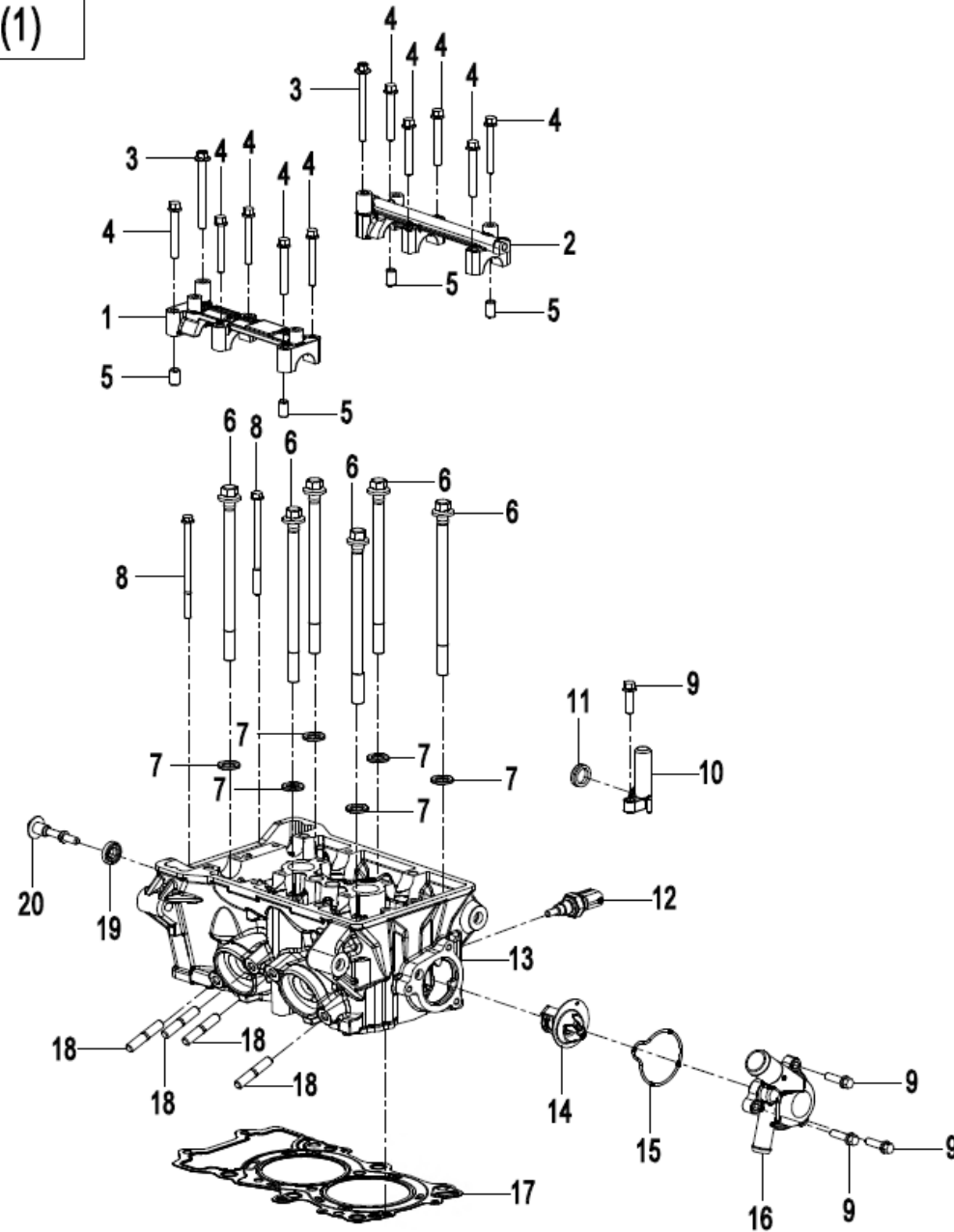

1/2/3/4/5/13
21



NO.	CODE	EN DESCRIPTION	QTY	REMARKS
E02-2-03	0SQV-022105-1000	BOLT M6x65	2	
E02-2-04	0SQV-022106-1001	HEX FLANGE BOLT M6x45	10	
E02-2-05	0010-080008	DOWEL PIN 8X14	4	
E02-2-06	0SQV-022008-1000	CYLINDER HEAD BOLT M10X150	6	
E02-2-07	0700-022016	WASHER 10.5x19x2.3	6	
E02-2-08	0SQV-022011-1000	BOLT M6x90	2	
E02-2-09	0010-023010-0010	BOLT M6x20	4	
E02-2-10	0SQV-022200-1000	CONNECTOR ASSY.	1	
E02-2-11	1F30-024016	OIL SEAL, SURFACE	1	
E02-2-12	018B-022810	WATER TEMPERATURE SENSOR	1	
E02-2-14	0MQ0-022500	THERMOSTAT	1	
E02-2-15	0SQV-022002-1000	SEAL RING, THERMOSTAT CAP	1	
E02-2-16	0SQV-022001-1000-0BP00	THERMOSTAT CAP (MIST SILVER BLACK)	1	
E02-2-17	0SQV-022300-1000	GASKET, CYLINDER HEAD	1	
E02-2-18	0180-022003-00001	STUD	4	
E02-2-19	0700-021200	CYLINDER HEAD COVER BOLT SEAL RING	1	
E02-2-20	0DM0-022008-00001	CYLINDER HEAD DAMPING BOLT	1	
E02-2-21	0SQV-022100-1003-0BP00	CYLINDER HEAD ASSY	1	

气缸盖分总成(2)/CYLINDER HEAD(2)

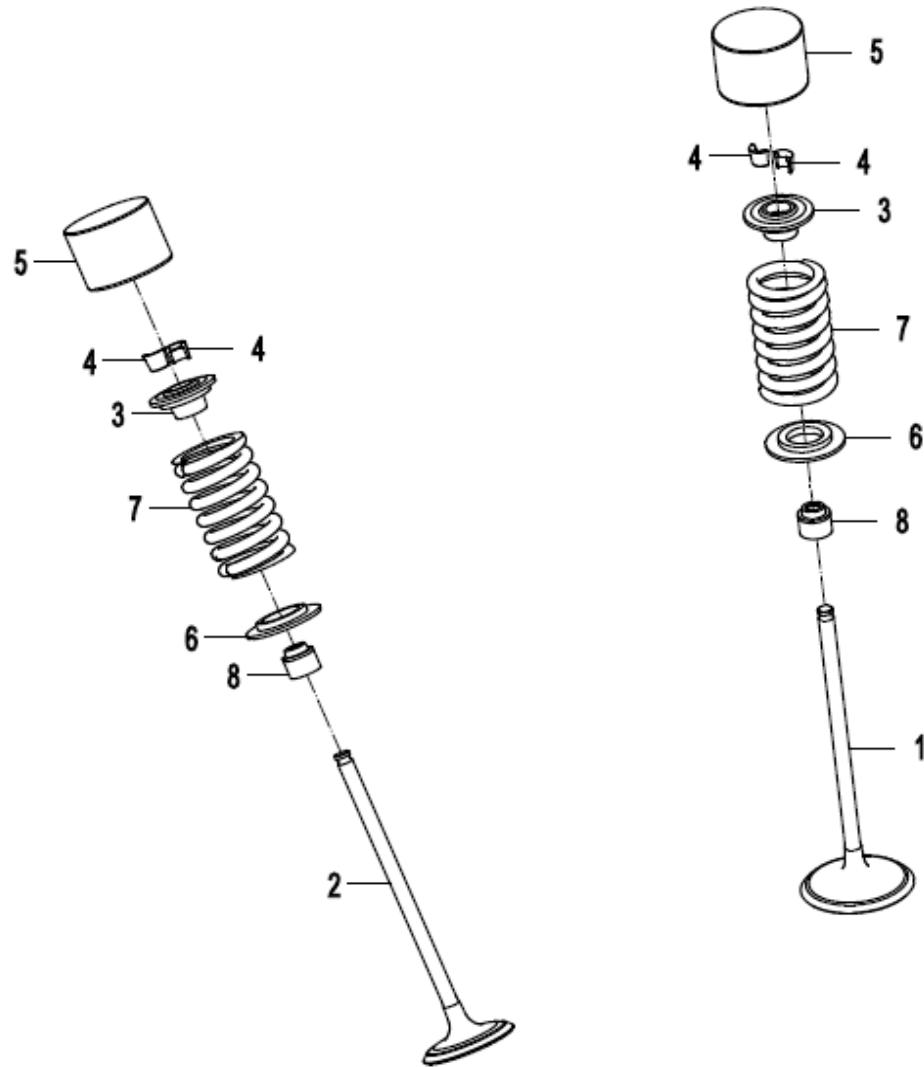

NO.	CODE	DESCRIPTION	QTY	REMARKS
E02-3-01	0SQV-022004-1000	VALVE, INTAKE	4	
E02-3-02	0SQV-022005-1000	VALVE, EXHAUST	4	
E02-3-03	0MQ0-022003	UPPER SEAT, VALVE SPRING	8	
E02-3-04	0700-022004	LOCK CLIP, VALVE	16	
E02-3-05	0MQ0-022005-0370	TAPPET T=3.94	8	
E02-3-05	0MQ0-022005-0380	TAPPET T=3.96	8	
E02-3-05	0MQ0-022005-0390	TAPPET T=3.98	8	
E02-3-05	0MQ0-022005-0400	TAPPET T=4.00	8	
E02-3-05	0MQ0-022005-0410	TAPPET T=4.02	8	
E02-3-05	0MQ0-022005-0420	TAPPET T=4.04	8	
E02-3-05	0MQ0-022005-0430	TAPPET T=4.06	8	
E02-3-05	0MQ0-022005-0440	TAPPET T=4.08	8	
E02-3-05	0MQ0-022005-0450	TAPPET T=4.10	8	
E02-3-05	0MQ0-022005-0460	TAPPET T=4.12	8	
E02-3-05	0MQ0-022005-0470	TAPPET T=4.14	8	
E02-3-05	0MQ0-022005-0480	TAPPET T=4.16	8	
E02-3-05	0MQ0-022005-0490	TAPPET T=4.18	8	
E02-3-05	0MQ0-022005-0070	TAPPET T=3.34	8	
E02-3-05	0MQ0-022005-0080	TAPPET T=3.36	8	
E02-3-05	0MQ0-022005-0090	TAPPET T=3.38	8	
E02-3-05	0MQ0-022005-0100	TAPPET T=3.40	8	
E02-3-05	0MQ0-022005-0110	TAPPET T=3.42	8	
E02-3-05	0MQ0-022005-0120	TAPPET T=3.44	8	
E02-3-05	0MQ0-022005-0130	TAPPET T=3.46	8	
E02-3-05	0MQ0-022005-0140	TAPPET T=3.48	8	
E02-3-05	0MQ0-022005-0150	TAPPET T=3.50	8	
E02-3-05	0MQ0-022005-0160	TAPPET T=3.52	8	
E02-3-05	0MQ0-022005-0170	TAPPET T=3.54	8	
E02-3-05	0MQ0-022005-0180	TAPPET T=3.56	8	
E02-3-05	0MQ0-022005-0190	TAPPET T=3.58	8	
E02-3-05	0MQ0-022005-0200	TAPPET T=3.60	8	
E02-3-05	0MQ0-022005-0210	TAPPET T=3.62	8	

NO.	CODE	DESCRIPTION	QTY	REMARKS
E02-3-05	0MQ0-022005-0220	TAPPET T=3.64	8	
E02-3-05	0MQ0-022005-0230	TAPPET T=3.66	8	
E02-3-05	0MQ0-022005-0240	TAPPET T=3.68	8	
E02-3-05	0MQ0-022005-0250	TAPPET T=3.70	8	
E02-3-05	0MQ0-022005-0260	TAPPET T=3.72	8	
E02-3-05	0MQ0-022005-0270	TAPPET T=3.74	8	
E02-3-05	0MQ0-022005-0280	TAPPET T=3.76	8	
E02-3-05	0MQ0-022005-0290	TAPPET T=3.78	8	
E02-3-05	0MQ0-022005-0300	TAPPET T=3.80	8	
E02-3-05	0MQ0-022005-0310	TAPPET T=3.82	8	
E02-3-05	0MQ0-022005-0320	TAPPET T=3.84	8	
E02-3-05	0MQ0-022005-0330	TAPPET T=3.86	8	
E02-3-05	0MQ0-022005-0340	TAPPET T=3.88	8	
E02-3-05	0MQ0-022005-0350	TAPPET T=3.90	8	
E02-3-05	0MQ0-022005-0360	TAPPET T=3.92	8	
E02-3-06	0SQV-022006-1000	LOWER SEAT, VALVE SPRING	8	
E02-3-07	0SQV-022003-1000-10	VALVE SPRING	8	
E02-3-08	0700-022400-1000	SEAL RING, VALVE STEM	8	

气缸盖分总成(4)/CYLINDER HEAD(4)

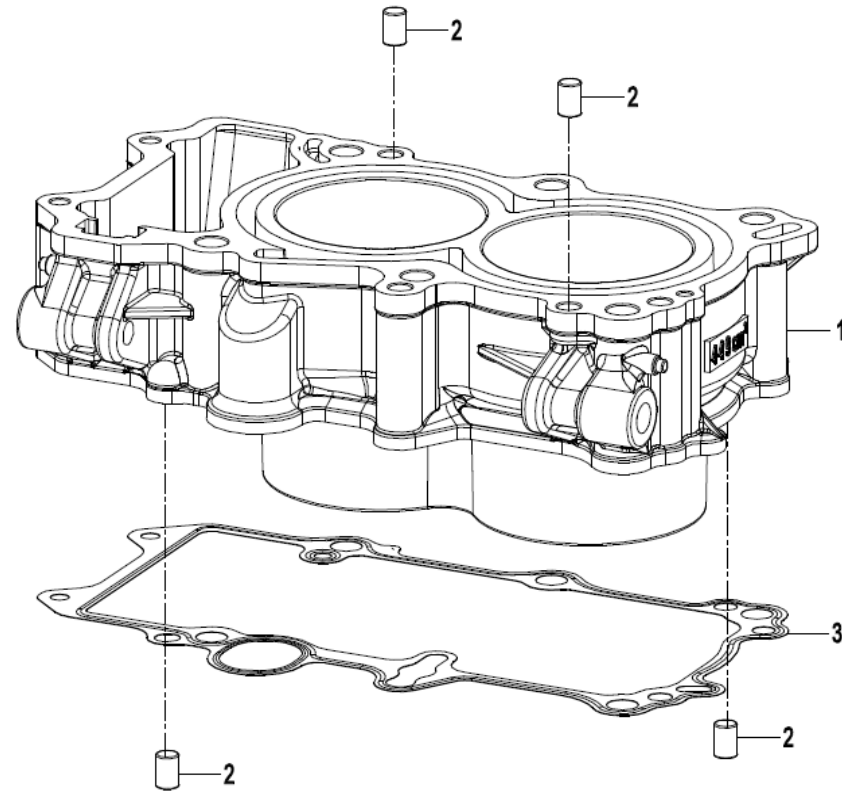

NO.	CODE	EN DESCRIPTION	QTY	REMARKS
E02-4-01	OSQV-023001-1000-0BP00	CYLINDER BODY	1	
E02-4-02	30410-00800	ROLLER	4	
E02-4-03	OSQV-023002-1000	GASKET, CYLINDER	1	

配气传动分总成/CAMSHAFT

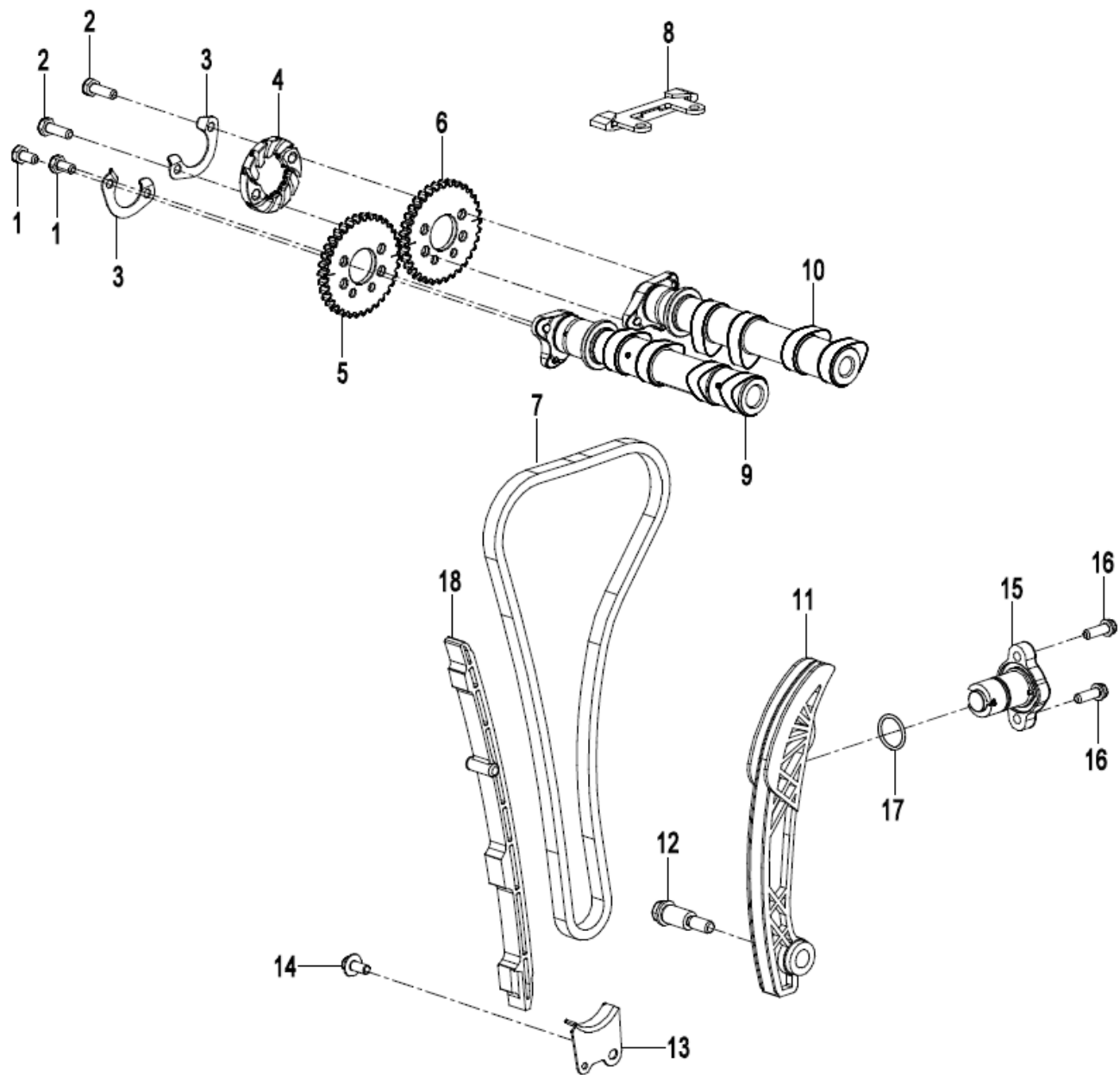

NO.	CODE	EN DESCRIPTION	QTY	REMARKS
E02-5-01	30004-060012150	BOLT	2	
E02-5-02	1F30-024012	BOLT M6x18	2	
E02-5-03	0700-024003	RETAINER	2	
E02-5-04	0SQV-024013-1001	CENTRIFUGAL WHEEL	1	
E02-5-05	0SQV-024002-1000	AIR OUTLET TIMING SPROCKET	1	
E02-5-06	0SQV-024001-1000	AIR INLET TIMING SPROCKET	1	
E02-5-07	0SQV-024200-1000	TIMING CHAIN	1	
E02-5-08	0SQV-024100-1000	CHAIN GUIDE BLOCK	1	
E02-5-09	0SQV-024600-1001	CAMSHAFT, AIR EXHAUST	1	ALT:- 0SQV-024600-1000
E02-5-10	0SQV-024500-1001	CAMSHAFT, AIR INLET	1	ALT:- 0SQV-024500-1000
E02-5-11	0SQV-024005-1001	TENSION PLATE	1	
E02-5-12	0SQV-024009-1000	PIN SHAFT	1	
E02-5-13	0SQV-024008-1000	PLATE, TIMING CHAIN	1	
E02-5-14	0010-021019-0010	BOLT M6x12	1	
E02-5-15	0SQV-024400-1001	HYDRAULIC TENSIONOR	1	
E02-5-16	0010-023010-0010	BOLT M6x20	2	
E02-5-17	0SQV-024401-1000	GASKET, HYDRAULIC TENSIONER	1	
E02-5-18	0SQV-024003-1001	CHAIN GUARD	1	

磁电机总成/FLYWHEEL

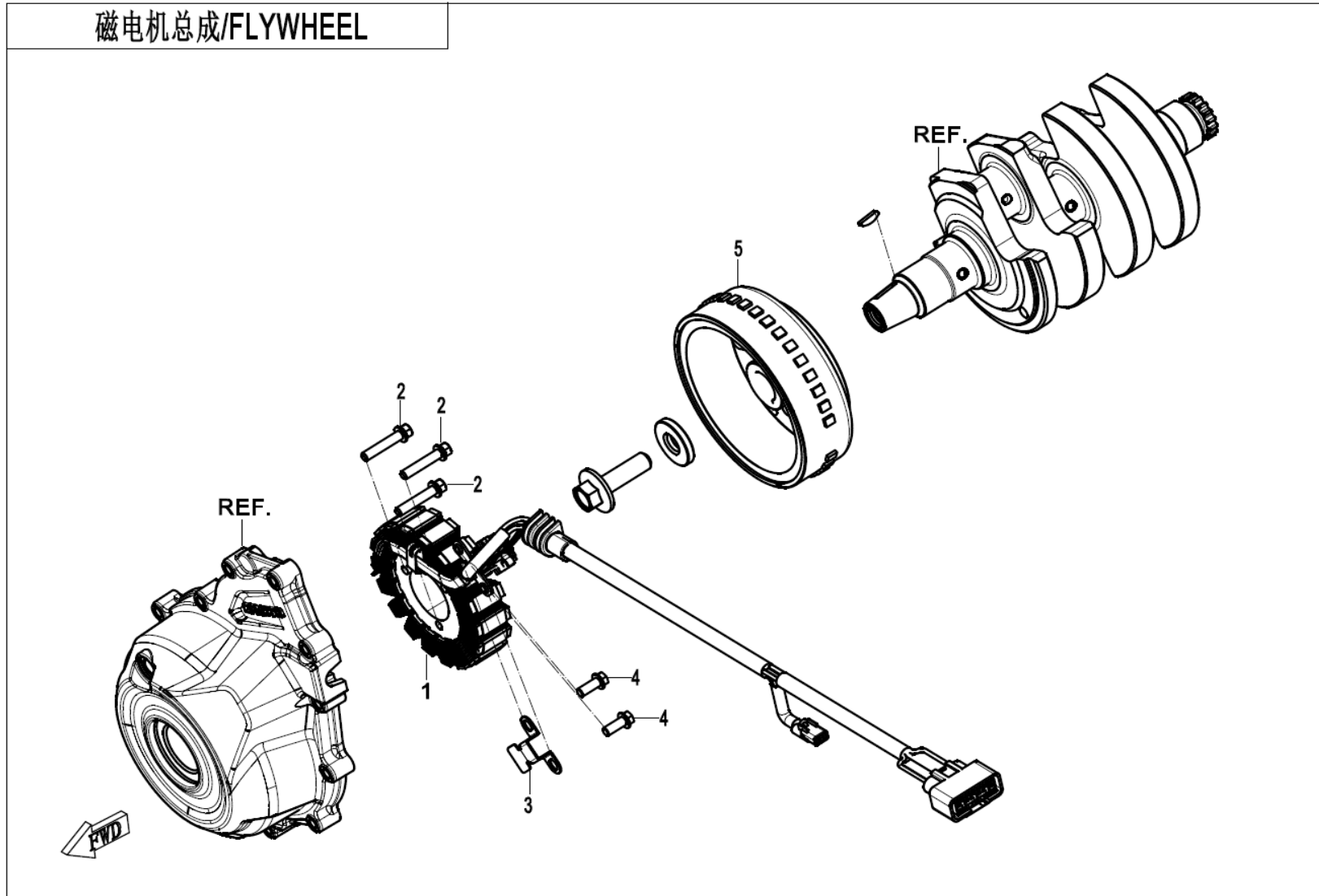

NO.	CODE	EN DESCRIPTION	QTY	REMARKS
E03-01	0SQV-032000-1001-10	MAGNETO STATOR ASSY	1	
E03-02	0180-030001-00001	BOLT M6X30	3	
E03-03	0SQV-032100-1000	STATER WIRE PRESS PLATE	1	
E03-04	0010-030002-00001	BOLT M5X16	2	
E03-05	0SQV-031000-1001	MAGNETO ROTOR ASSY	1	

曲轴连杆总成(1)/CRANKSHAFT &CONNECTING ROD(1)

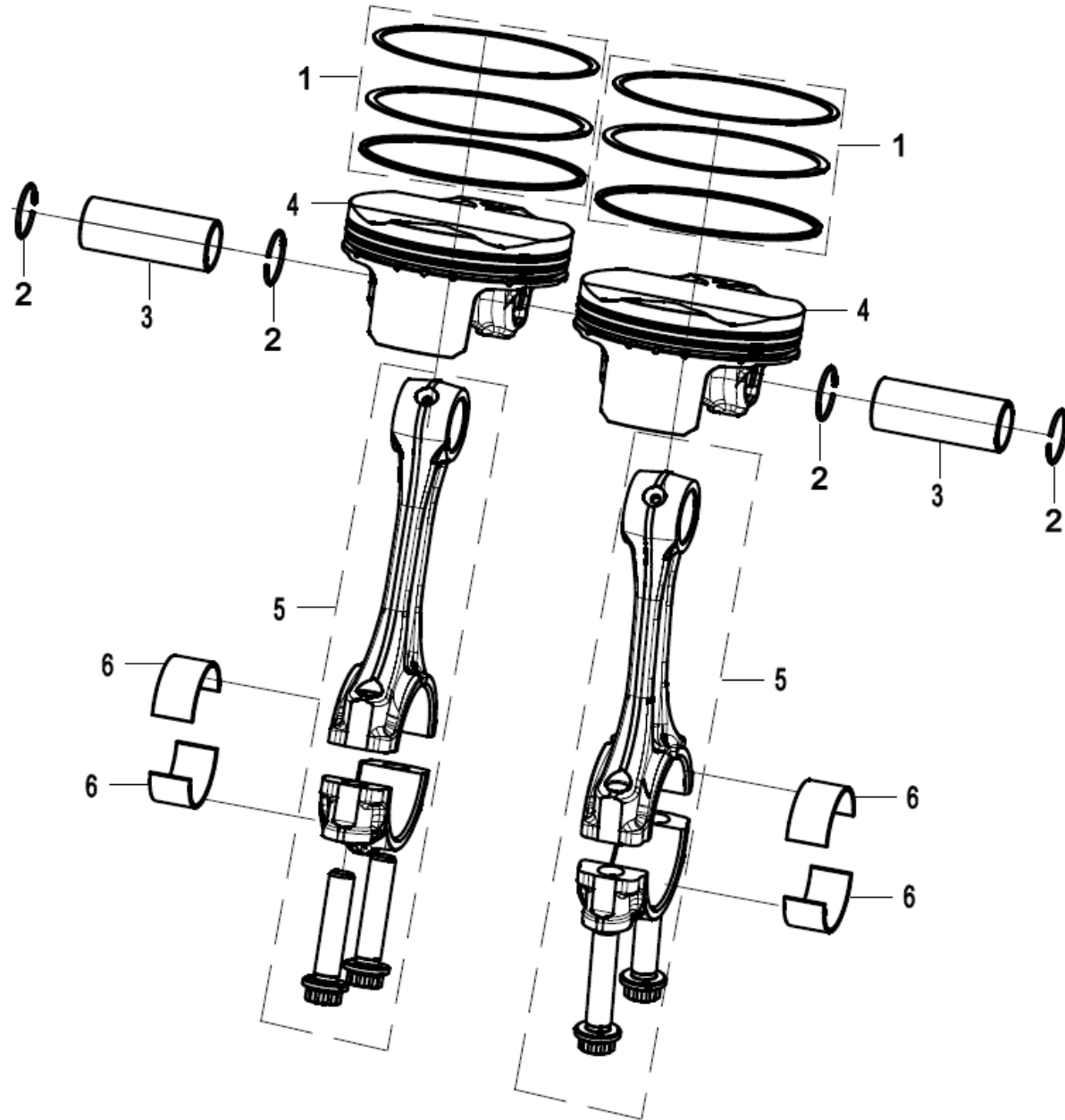

NO.	CODE	EN DESCRIPTION	QTY	REMARKS
E04-1-01	0SQV-040110-10A0	PISTON RING KIT	2	
E04-1-02	0110-040006-0050	CIRCLIP, PISTON PIN	4	
E04-1-03	0SQV-040008-1000	PISTON PIN	2	
E04-1-04	0SQV-040007-1001-Q0-00001	PISTON (MARK I)	2	
E04-1-04	0SQV-040007-1001-Q0-00002	PISTON	2	
E04-1-05	0SQV-042000-1001-Q0-00001	CONNECTING ROD ASSY	2	
E04-1-05	0SQV-042000-1001-Q0-00002	CONNECTING ROD ASSY	2	
E04-1-06	0SQV-040009-1000-Q0-00001	PLAIN BEARING, CONNECTING ROD (RED)	4	
E04-1-06	0SQV-040009-1000-Q0-00002	PLAIN BEARING, CONNECTING ROD (BLACK)	4	
E04-1-06	0SQV-040009-1000-Q0-00003	PLAIN BEARING, CONNECTING ROD (BLUE)	4	

曲轴连杆总成(2)/CRANKSHAFT &CONNECTING ROD(2)

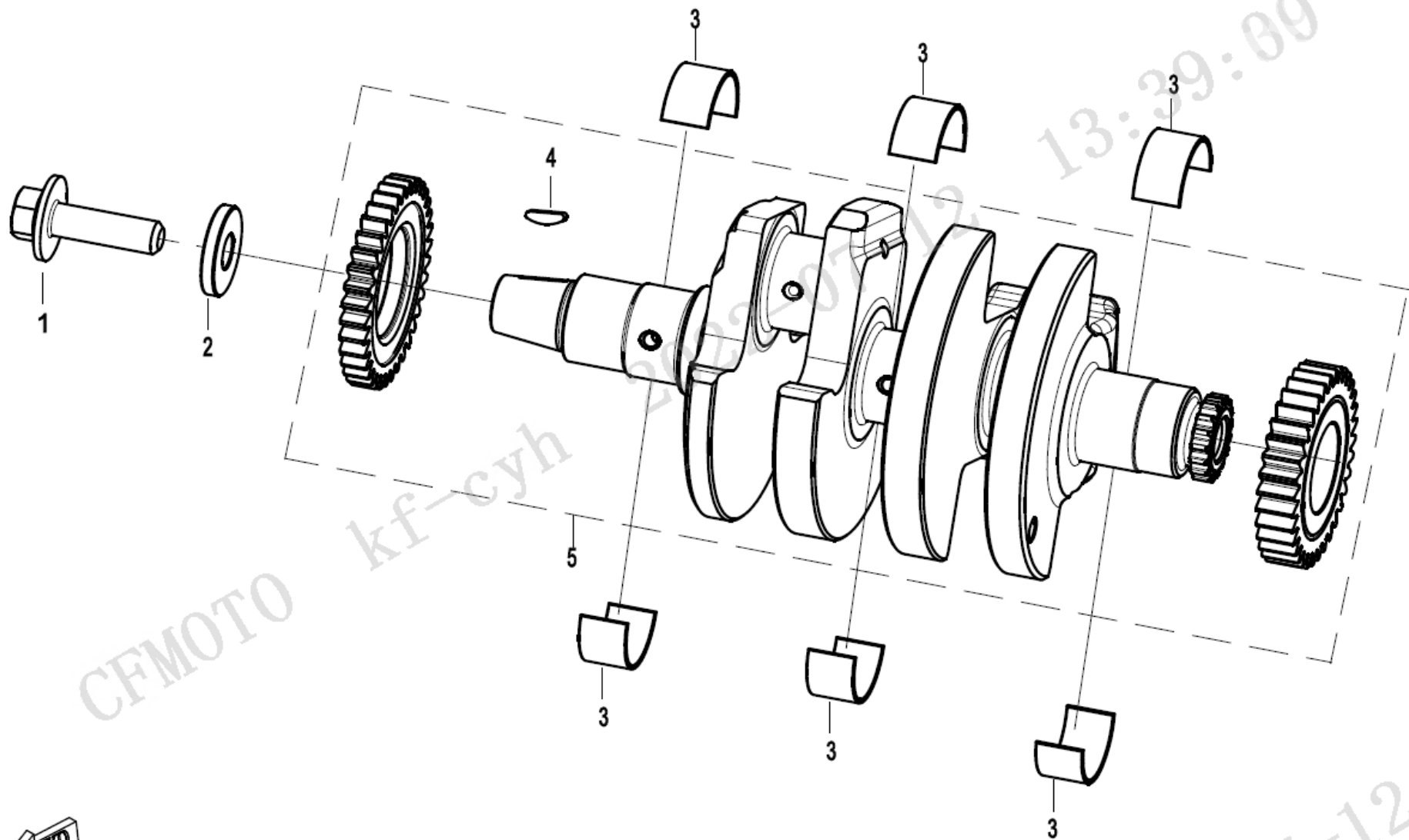

CFMOTO

kf-cyh

13:39:00

2012-07-12

NO.	CODE	EN DESCRIPTION	QTY	REMARKS
E04-2-01	0SQV-040001-1000	BOLT M12x1.25x40	1	
E04-2-02	0700-040002-00001	WASHER 12.5X33X5	1	
E04-2-03	0SQV-011001-1000-Q0-00001	PLAIN BEARING, MAIN SHAFT (RED)	6	
E04-2-03	0SQV-011001-1000-Q0-00002	PLAIN BEARING, MAIN SHAFT (BLACK)	6	
E04-2-03	0SQV-011001-1000-Q0-00003	PLAIN BEARING, MAIN SHAFT (BLUE)	6	
E04-2-04	0180-040007	WOODRUFF KEY	1	
E04-2-05	0SQV-041000-1002	CRANKSHAFT ASSY	1	

离合器总成/CLUTCH ASSY

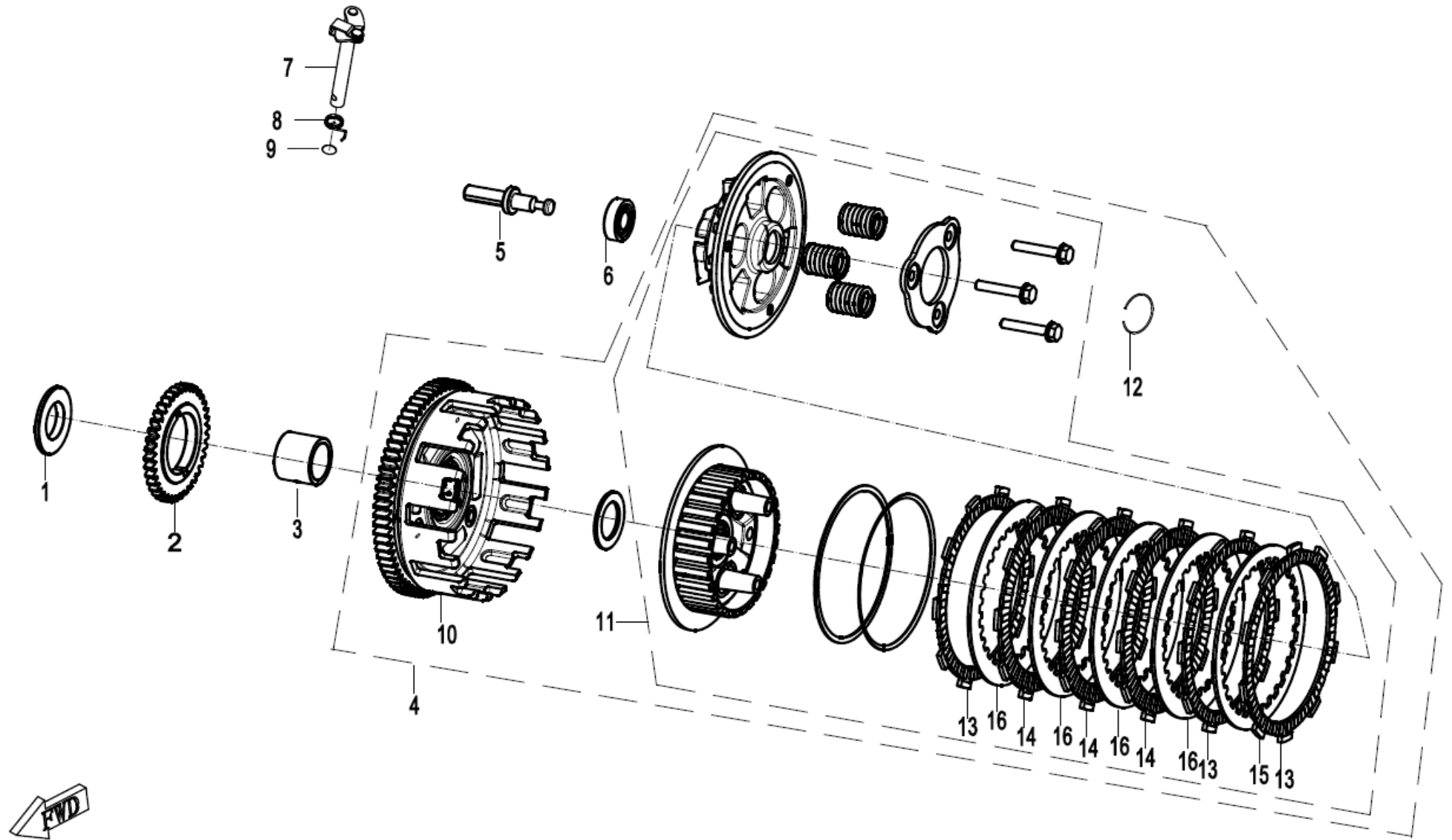

NO.	CODE	EN DESCRIPTION	QTY	REMARKS
E05-01	0SQV-050001-1000	WASHER 25.2X46X5.8	1	
E05-02	0SQV-050005-1001	DRIVE GEAR, OIL PUMP	1	
E05-02	0SQV-050005-1000-10	DRIVE GEAR, OIL PUMP	1	
E05-03	0SQV-050002-1000	AXLE SLEEVE, CLUTCH	1	
E05-04	0SQV-051000-1000-Q1-00001	CLUTCH SUB ASSY (MARK A)	1	
E05-04	0SQV-051000-1000-Q1-00002	CLUTCH SUB ASSY (MARK B)	1	
E05-05	0SQV-050004-1001	ROD	1	
E05-06	30400-01207	ROLLER BEARING	1	
E05-07	0SQV-050100-1000	CLUTCH CONTROL SHAFT ASSY	1	
E05-08	0700-013006-10000	RETURN SPRING, CLUTCH CONTROL LEVER	1	
E05-09	0700-013007	WASHER 12.5X18.5X0.6	1	
E05-10	0SQV-051100-1000-M1	PRIMARY DRIVEN PULLEY ASSY	1	
E05-11	0SQV-051200-1000-M1	CENTRAL SLEEVE ASSY	1	
E05-12	0SQV-060004-1000	LOCK WASHER	1	
E05-13	0SQV-051210-1000-M1	FRICTION DISC ASSY 1	3	
E05-14	0SQV-051220-1000-M1	FRICTION DISC ASSY 2	3	
E05-15	0SQV-051213-1000-M1	DRIVEN DISC 1	1	
E05-16	0SQV-051214-1000-M1	DRIVEN DISC 2	4	

换档变速总成(1)/TRANSMISSION SYSTEM(1)

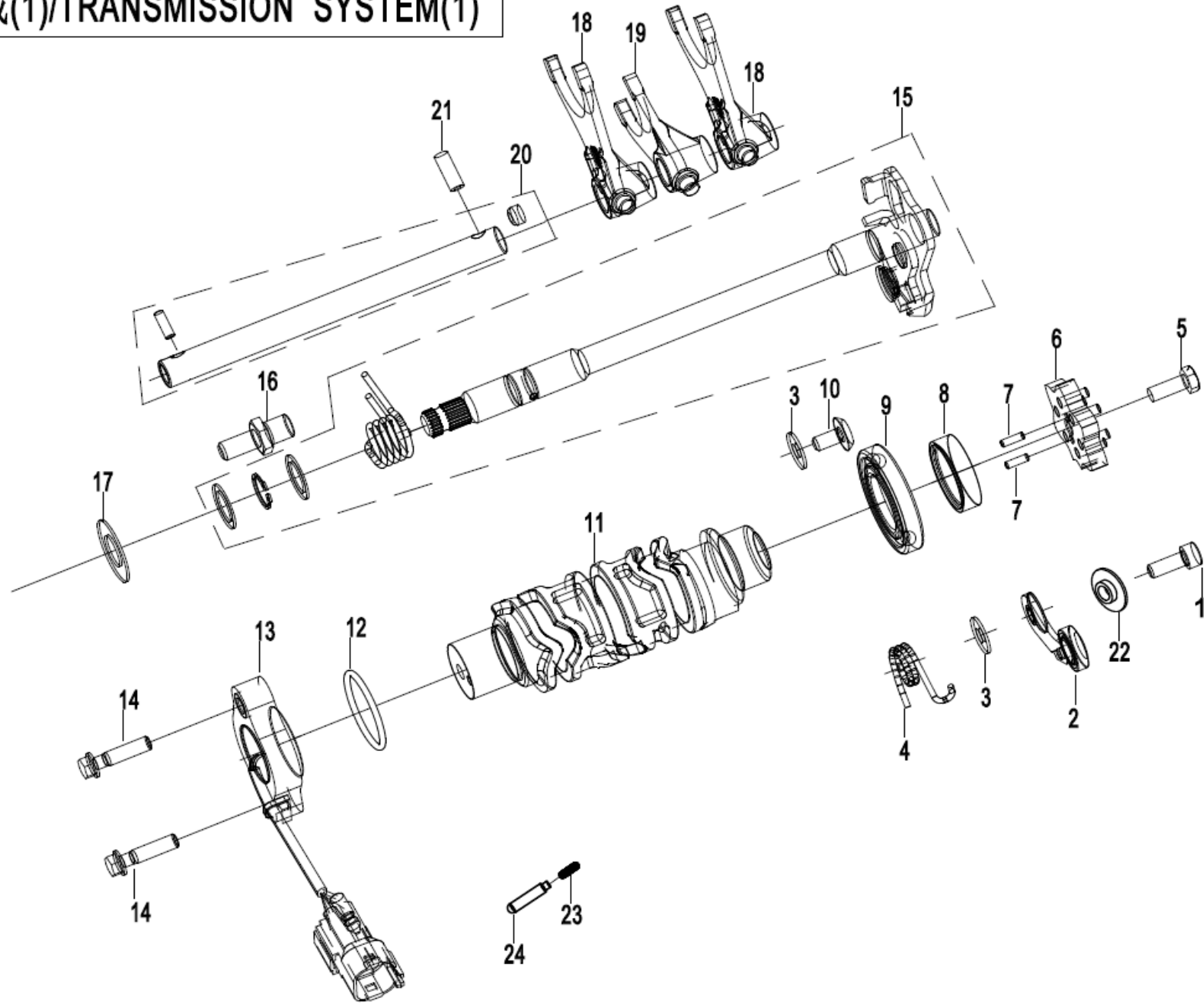

NO.	CODE	EN DESCRIPTION	QTY	REMARKS
E06-1-01	30102-060016810	SCREW M6X16	1	
E06-1-02	0SQV-065100-1001	SPRING, ROCKER ARM	1	ALT:- 0SQV-065100-1000
E06-1-03	0700-064001	WASHER 6.3X16.3X1.2	2	
E06-1-04	ODM0-065001	SPRING, SWING ARM, GEARSHIFT	1	
E06-1-05	30004-060016130	BOLT M6x16	1	
E06-1-06	0SQV-064100-1002	CAM, GEARSHIFT DRUM	1	
E06-1-07	30406-00303	NEEDLE BEARING	2	
E06-1-08	0SQV-064002-1000	SHIFT DRUM BUSHING	1	
E06-1-09	30400-02505	BEARING	1	
E06-1-10	0010-090005-0010	BOLT M6x16	1	
E06-1-11	0SQV-064001-1001	SHIFT DRUM	1	
E06-1-12	0SQV-060012-1000	O-RING 31X2.5	1	
E06-1-13	0SQV-060400-1001	GEAR SENSOR	1	
E06-1-14	0010-021017-0010	BOLT M6x25	2	
E06-1-15	0SQV-063000-1001	GEARSHIFT ROD	1	
E06-1-16	ODM0-063002-00001	SHIFT POSITION SPRING PIN	1	
E06-1-17	0SQV-060013-1000	WASHER 14X28X1	1	
E06-1-18	0SQV-060002-1000	SHIFT FORK (LH & RH)	2	
E06-1-19	0SQV-060003-1000	SHIFT FORK (MIDDLE)	1	
E06-1-20	0SQV-060102-1002	FORK SHAFT	1	
E06-1-21	0SQV-060015-1001	DOWEL PIN 6	1	
E06-1-22	0700-064003-00001	SLEEVE, SWING ARM, GEARSHIFT	1	
E06-1-23	0700-063007	SPRING, CONTACTOR	1	
E06-1-24	0700-063008	BALL CONTACTOR	1	

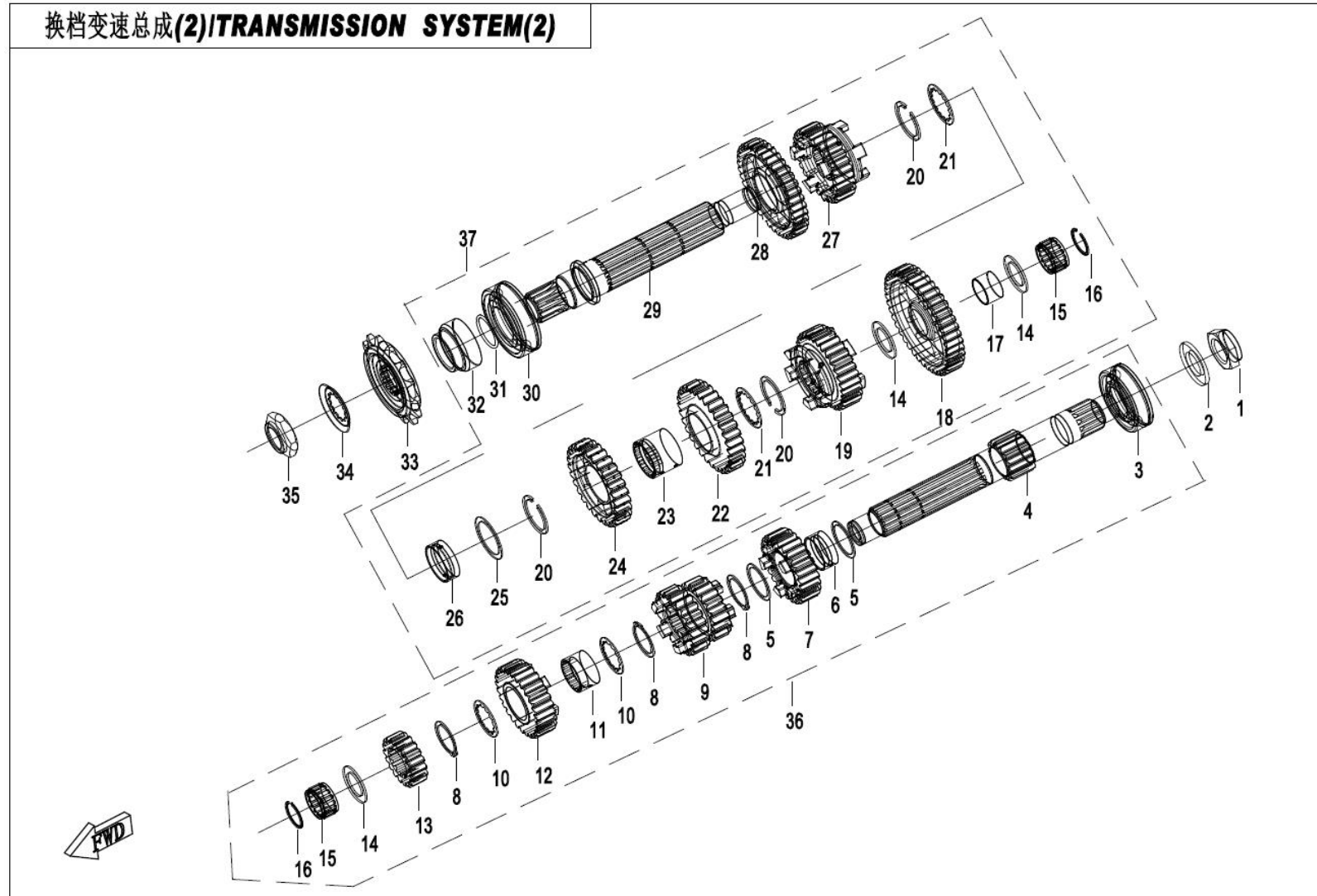

NO.	CODE	EN DESCRIPTION	QTY	REMARKS
E06-2-01	0700-061002-00002	NUT M20X1.5	1	
E06-2-02	0700-061003	CIRCLIP 20	1	
E06-2-03	0SQV-061012-1000-10	MAIN SHAFT BEARING	1	ALT:- 0SQV-061012-1000
E06-2-04	0SQV-061001-1000	MAIN SHAFT	1	
E06-2-05	0SQV-061008-1000	WASHER	2	

NO.	CODE	EN DESCRIPTION	QTY	REMARKS
E06-2-06	OSQV-061011-1000	BUSHING	1	
E06-2-07	OSQV-061009-1000	5TH GEAR, MAIN SHAFT	1	
E06-2-08	ODM0-062017	CIRCLIPS FOR SHAFT 25	3	
E06-2-09	OSQV-061007-1000	3RD4TH GEAR, MAIN SHAFT	1	
E06-2-10	ODM0-062016	SPLINE WASHER 25x31x1	2	
E06-2-11	OSQV-061006-1000	SPLINE SLEEVE	1	
E06-2-12	OSQV-061005-1000	6TH GEAR, MAIN SHAFT	1	
E06-2-13	OSQV-061003-1000	2ND GEAR, MAIN SHAFT	1	
E06-2-14	OSQV-061002-1000	WASHER	3	
E06-2-15	30499-02004	NEEDLE BEARING	2	
E06-2-16	0700-061016	CIRCLIPS FOR SHAFT20	2	
E06-2-17	OSQV-062102-1000	SHAFT SLEEVE	1	
E06-2-18	OSQV-062101-1000	1ST GEAR, COUNTERSHAFT	1	
E06-2-19	OSQV-062013-1000	5TH GEAR, COUNTERSHAFT	1	
E06-2-20	30801-02805	CIRCLIPS FOR SHAFT 28	3	
E06-2-21	OSQV-062008-1000	WASHER, SPLINE	2	
E06-2-22	OSQV-062012-1000	3RD GEAR, COUNTERSHAFT	1	
E06-2-23	OSQV-062011-1000	SPLINE SLEEVE	1	
E06-2-24	OSQV-062009-1000	4TH GEAR, COUNTERSHAFT	1	
E06-2-25	OSQV-062006-1000	28.2x36x1	1	
E06-2-26	OSQV-062005-1000	28x10.5	1	
E06-2-27	OSQV-062007-1001	6TH GEAR, COUNTERSHAFT	1	
E06-2-28	OSQV-062004-1000	2ND, COUNTERSHAFT	1	
E06-2-29	OSQV-062001-1001	COUNTERSHAFT	1	
E06-2-30	OSQV-062003-1000-10	COUNTERSHAFT BEARING 62x28	1	ALT:- OSQV-062003-1000
E06-2-31	0800-062205	O-RING	1	
E06-2-32	OSQV-062002-1000	SHAFT SLEEVE, COUNTERSHAFT	1	
E06-2-33	0MQ0-062030	SPROCKET, OUTPUT	1	
E06-2-34	0700-062015	WASHER	1	
E06-2-35	OSQV-060014-1001	NUT M20x1.5	1	ALT:- OSQV-060014-1000
E06-2-36	OSQV-061000-1000-10	MAIN SHAFT ASSY	1	
E06-2-37	OSQV-062000-1000-10	COUNTERSHAFT ASSY	1	

润滑系统总成/LUBRICATION SYSTEM

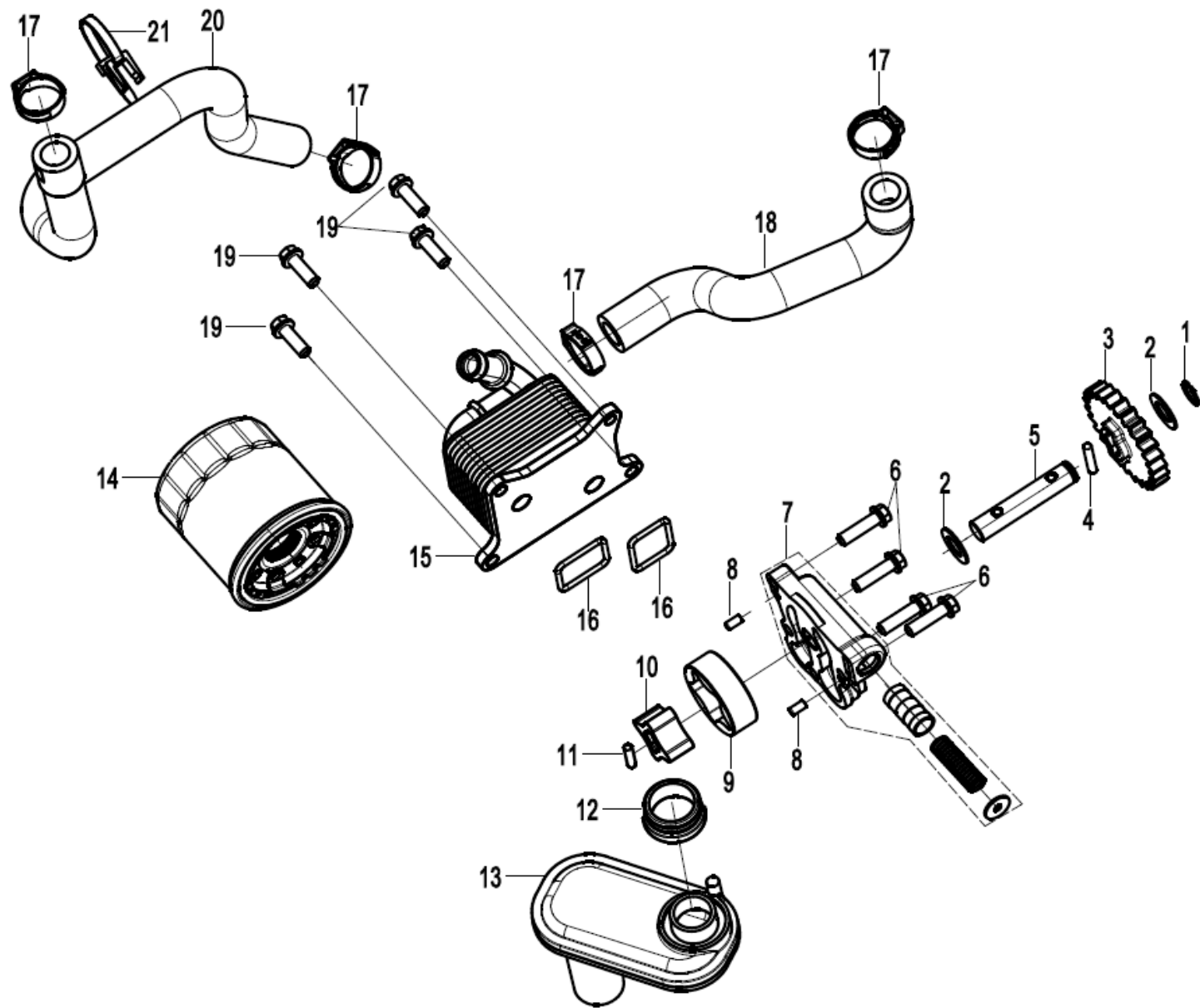

NO.	CODE	EN DESCRIPTION	QTY	REMARKS
E07-01	30801-01100	CIRCLIPS FOR SHAFT 11	1	
E07-02	0SQV-071003-1000	WASHER 11X20X1	2	
E07-03	0SQV-071001-1001	GEAR, OIL PUMP	1	
E07-04	30406-00402	ROLLER NEEDLE P4x21.8	1	
E07-05	0SQV-071002-1000	SHAFT, OIL PUMP	1	
E07-06	0010-023010-0010	BOLT M6x20	4	
E07-07	0SQV-071101-10A0	OIL PUMP COVER ASSY	1	
E07-08	30406-00401	ROLLER NEEDLE P4x7.8	2	ALT:- 920301-40078-PG2
E07-09	0700-071003	OUTER ROTOR, MAIN OIL PUMP	1	
E07-10	0700-071004	INNER ROTOR, MAIN OIL PUMP	1	
E07-11	30406-00400	ROLLER NEEDLE P4x15.8	1	
E07-12	0700-070101-00001	GASKET, OIL SUCTION PAN	1	
E07-13	0SQV-073100-1000	FILTER	1	
E07-14	0700-070200	OIL FILTER	1	
E07-15	0SQV-072100-1000	OIL COOLER	1	
E07-16	0SQV-072003-1000	SEAL RING, OIL COOLER	2	
E07-17	0SQV-028002-1000-M1	CLAMP Dia 22.5	4	
E07-18	0SQV-072001-1000	WATER OUTLET PIPE, OIL COOLER	1	
E07-19	0010-023008-00001	BOLT M6X18	4	ALT:- 0010-023008-0010
E07-20	0SQV-072002-1000	WATER INLET PIPE, OIL COOLER	1	

水泵总成/WATER PUMP

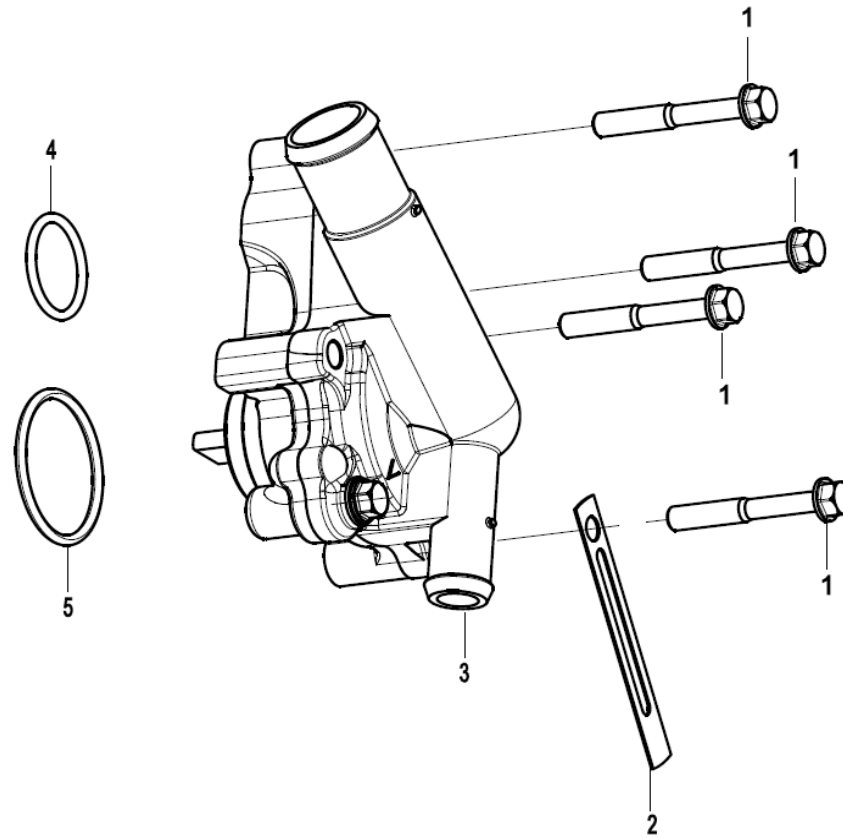

NO.	CODE	EN DESCRIPTION	QTY	REMARKS
E08-01	OHTB-065202	BOLT M6x42	4	
E08-02	0180-014010	WIRE CLIP	1	
E08-03	OSQV-081000-1001-0BU00	WATER PUMP SUB ASSY	1	
E08-04	OSQV-081009-1000	O-RING	1	
E08-05	OSQV-080002-1000	O-RING 33x2.65	1	

启动系统总成/STARTING SYSTEM

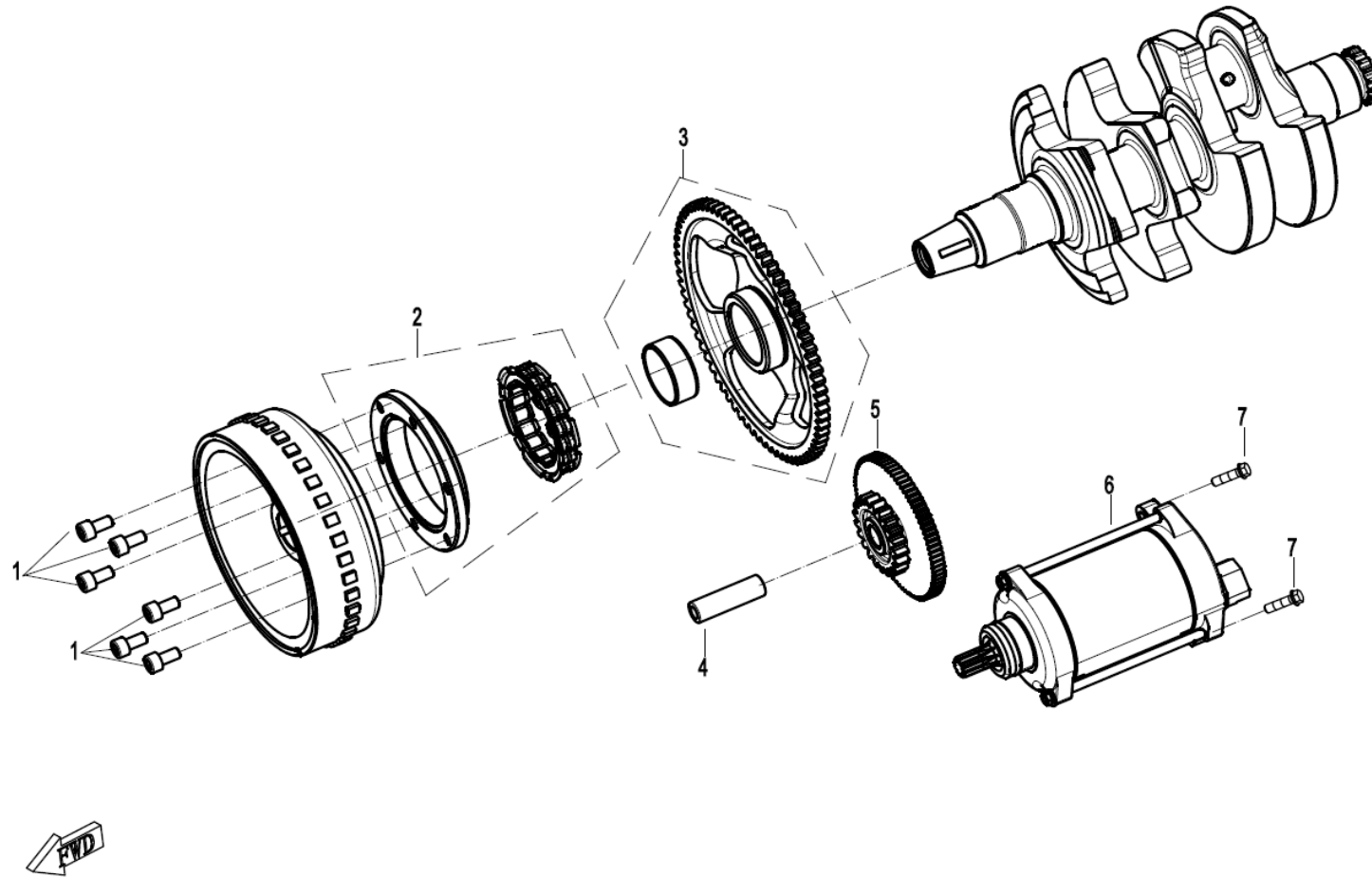

NO.	CODE	EN DESCRIPTION	QTY	REMARKS
E09-01	30102-060012810	SCREW M6X12	6	
E09-02	0SQV-091000-1001	OVERRIDING CLUTCH ASSY	1	
E09-03	0SQV-092000-1002	GEAR, STARTING MOTOR	1	ALT:- 0SQV-092000-1001
E09-04	0700-090003	SHAFT, MIDDLE GEAR	1	
E09-05	0SQV-090001-1000	DUAL GEAR	1	
E09-06	0SQV-093000-1000	STARTING MOTOR	1	
E09-07	0010-021017-0010	BOLT M6x25	2	

E16 平衡轴总成 BALANCER SHAFT

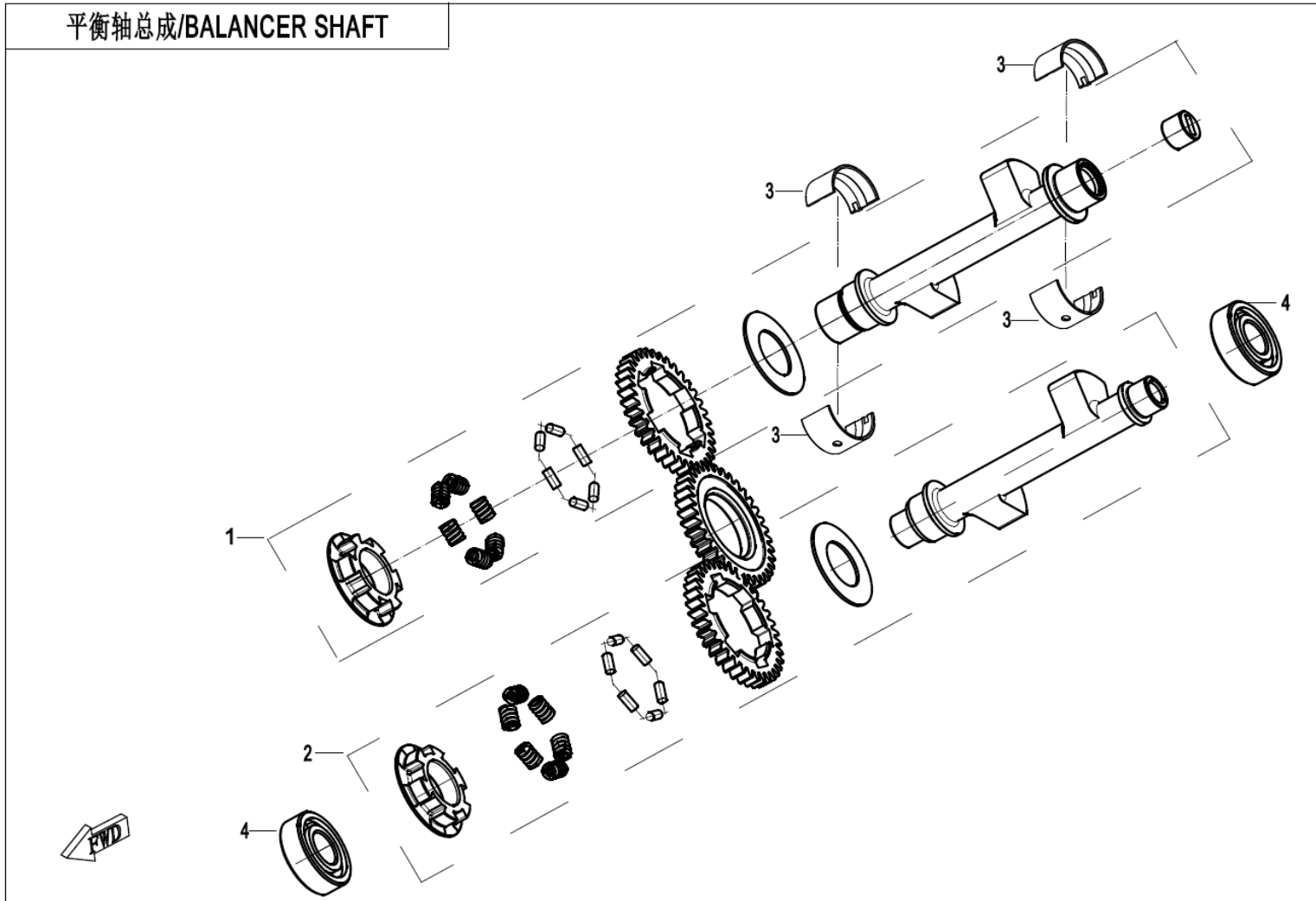

NO.	CODE	EN DESCRIPTION	QTY	REMARKS
E16-01	OSQV-161000-1002	FRONT BALANCING SHAFT ASSY	1	ALT:- OSQV-161000-1001
E16-02	OSQV-162000-1001	REAR BALANCING SHAFT	1	
E16-03	OSQV-011002-1000-Q0-00001	PLAIN BEARING, BALANCER SHAFT (RED)	4	
E16-03	OSQV-011002-1000-Q0-00002	PLAIN BEARING, BALANCER SHAFT (BLACK)	4	
E16-03	OSQV-011002-1000-Q0-00003	PLAIN BEARING, BALANCER SHAFT (BLUE)	4	
E16-03	30400-02009	BEARING	2	

节气门阀体和喷油器/THROTTLE&INJECTOR

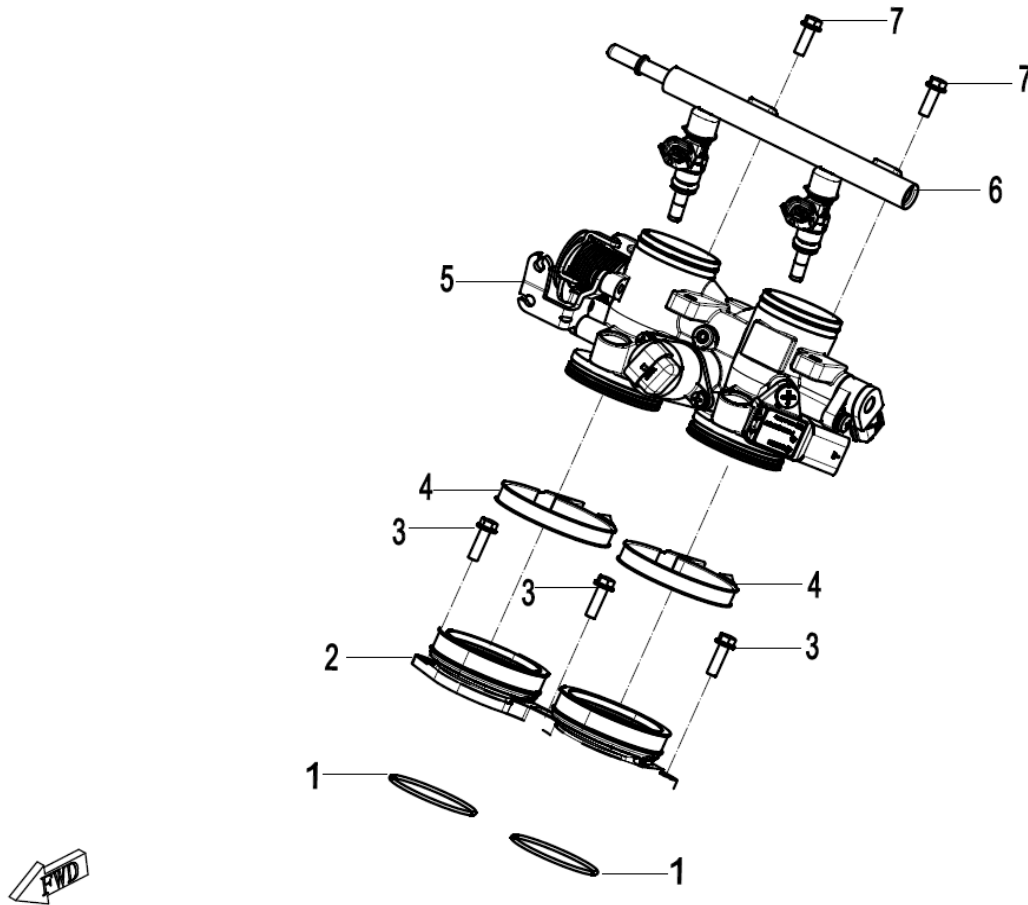

NO.	CODE	EN DESCRIPTION	QTY	REMARKS
E17-01	0SQV-022009-1000	O-RING 46.2X2	2	
E17-02	0SQV-022400-1000	CONNECTING PIPE, THROTTLE BODY	1	
E17-03	0010-023008-00001	BOLT M6X18	3	ALT:- 0010-023008-0010
E17-04	0SQV-022410-1000	CLAMP 62	2	
E17-05	0SQV-173000-1000-10	THROTTLE BODY ASSY	1	
E17-06	0SQV-173200-1001	FUEL PIPE ASSY	1	
E17-07	0010-090005-0010	BOLT M6x16	1	